

Roof fans made of plastic



durable
 weather-proof
 application-optimised



Why HLU?

90 years of experience in the
plastics processing market

More than 10.000 m² production
in Germany

Worldwide partner network

Large performance spectrum
in air technology

Over 200 qualified employees

www.hlu.eu





Index

Type serie HF D ...-15 / 17 D	
Advantages, Design, Application	4
Specification	5
Size: 110 up to 315	6
Type serie HF D ...-16 D	
Advantages, Design, Application	18
Specification	19
Size: 160 up to 250 only for ATEX Zone 1	20
Size: 315 up to 400	26
Type serie HF D ...-13 D	
Advantages, Design, Application	32
Specification	33
Size: 500 up to 1000	34
Accessories	
Roof mounting	44
Wall bracket	51
Silencer for roof fans	52
Sound enclosure Outlet silencer	62
Automatic louver damper	64
Adapters	66
Horizontal mounting	68
Floor mounting feet	69
Shaft seal felt ring	70
Protective grid	70
Repair switch	71
Explosion protection ATEX	72

HF - Roof fans Type series HF D ...-15 / 17 D

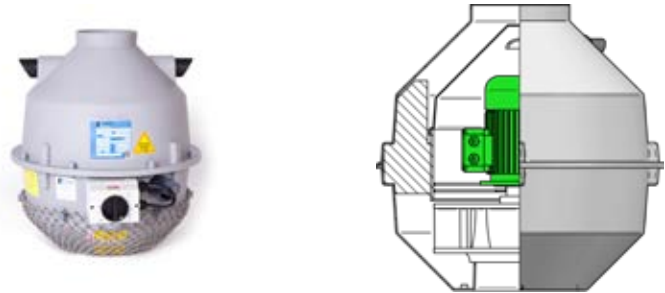

Advantages

- Weatherproof design
- Reliable drainage of rainwater
- Compact design
- Easy installation on flange
- Wide range of accessories available

Design

- Internal motors separated from the air flow
- No metal parts in the air flow
- Fitted as standard with repair switch or explosion-proof terminal box
- Use of explosion-proof motors possible

Application

- Ideal for the extraction of corrosive gases
- Extraction of potentially explosive atmosphere



Suction side of the fan with threaded bushings for flange mounting

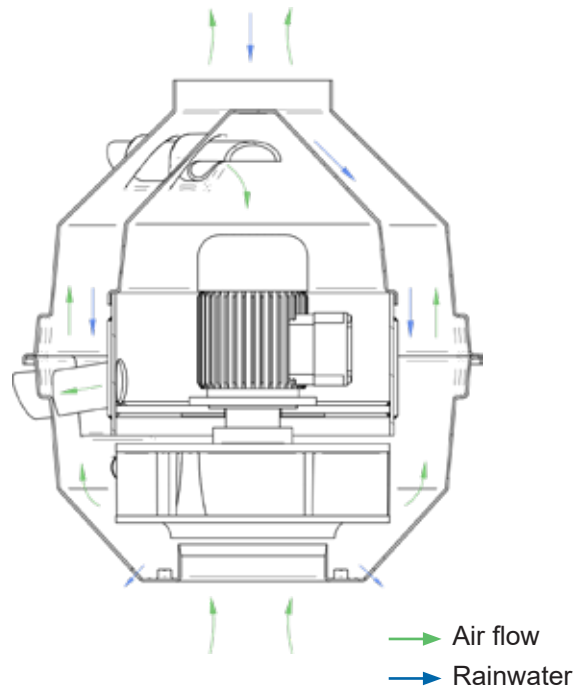

Accessories:



Roof mounting
DA1 without base
P. 44

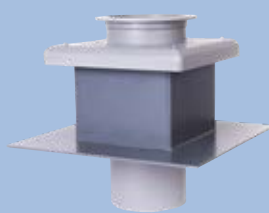

Roof mounting
DA2 with base
P. 46



Silencer for roof fans
P. 52

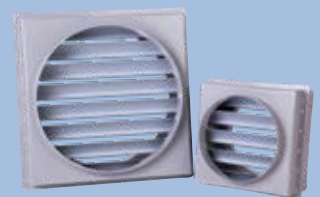

Automatic louver damper
JKS1
P. 64

Specification

HF - Roof fan

Corrosion resistant plastic radial roof fan with housing in stable, rotationally sintered version in PE-FR, one suction side, with splinter protection according to accident prevention rules from size 160 as plastic coated wire mesh. In case of upright mounting the exhaust air is blown out vertical according to requirements for aggressive air. All parts exposed to exhaust air made of plastic or encapsulated by plastic. Impeller with backward curved blades in injection moulded version, mounted with taper lock-bush on motor shaft, statically and dynamically balanced, quality of balancing at least G 6.3 (DIN ISO 21940-11). Including internally mounted motor, encapsulated against the delivery medium, and outside mounted repair switch in case of standard motors (without ex-protection) respectively externally mounted terminal box for ex-motors. External ventilation for the motor via outward located ducts.

Manufacturer	: Hürner Luft- und Umwelttechnik	
Type	: HF D ... - .. D	
Housing-material	: PEs	
Impeller-material	: PPs	
Inlet diameter	: ...	mm
Medium	: exhaust air	
Volume flow	: ...	m ³ /h
Total pressure difference	: ...	Pa
Static pressure difference	: ...	Pa
Sound pressure level Lp8A (1 m)	: ...	dB(A)
SFP	: ...	W/(m ³ /s)
Motor power	: ...	kW
Voltage	: 400	V
Frequency	: 50	Hz
Rated current	: ...	A
Enclosure / motor protection	: IP 55 / PTC	



Adaptor
P. 66



Shaft seal
felt ring
P. 70

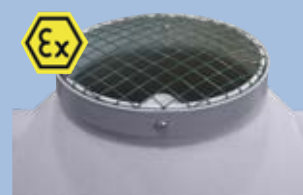

Protection grid
P. 70



Fans optionally available
for Ex-Zone!
P. 72

HF - Roof fan
Type series HF D ...-15 / 17 D

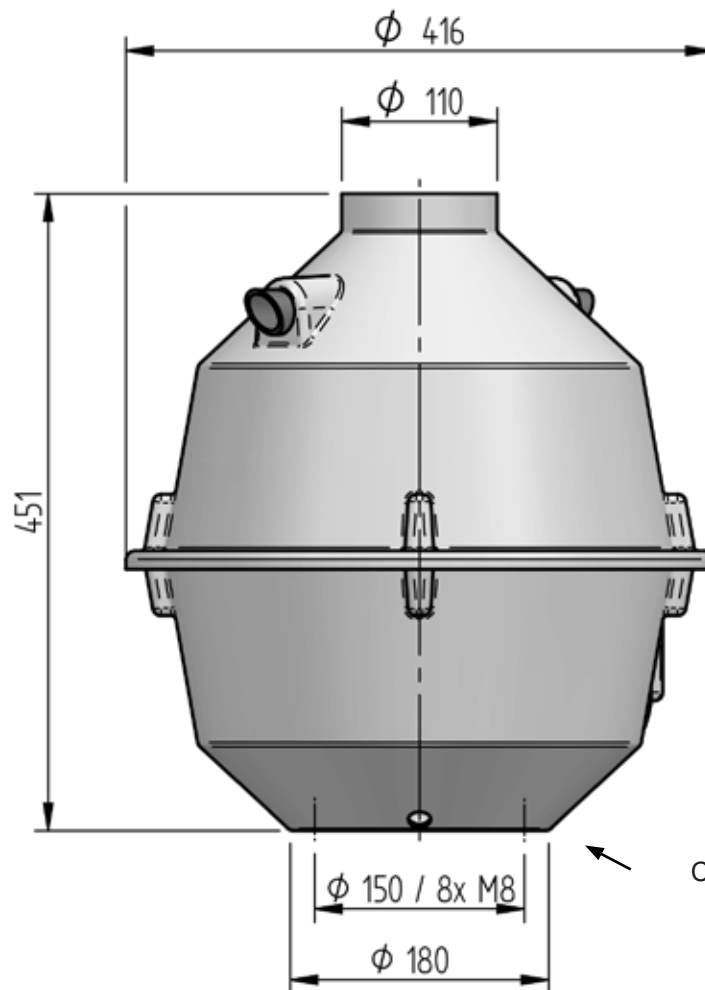
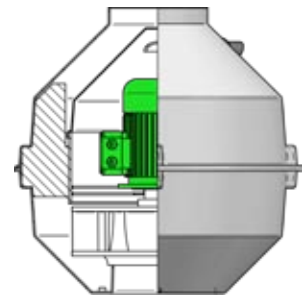

Connection diameter: \varnothing 110

Weight: ~ 9 kg

All dimensions in mm.

Accessories:



Roof mounting
DA1 without base
P. 44

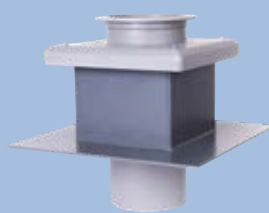

Roof mounting
DA2 with base
P. 46



Silencer for roof fans
P. 52

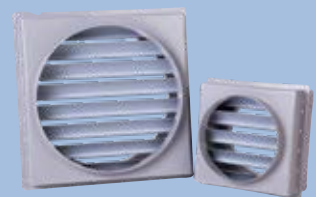

Automatic louver damper
JKS1
P. 64

HF D 110-17 D

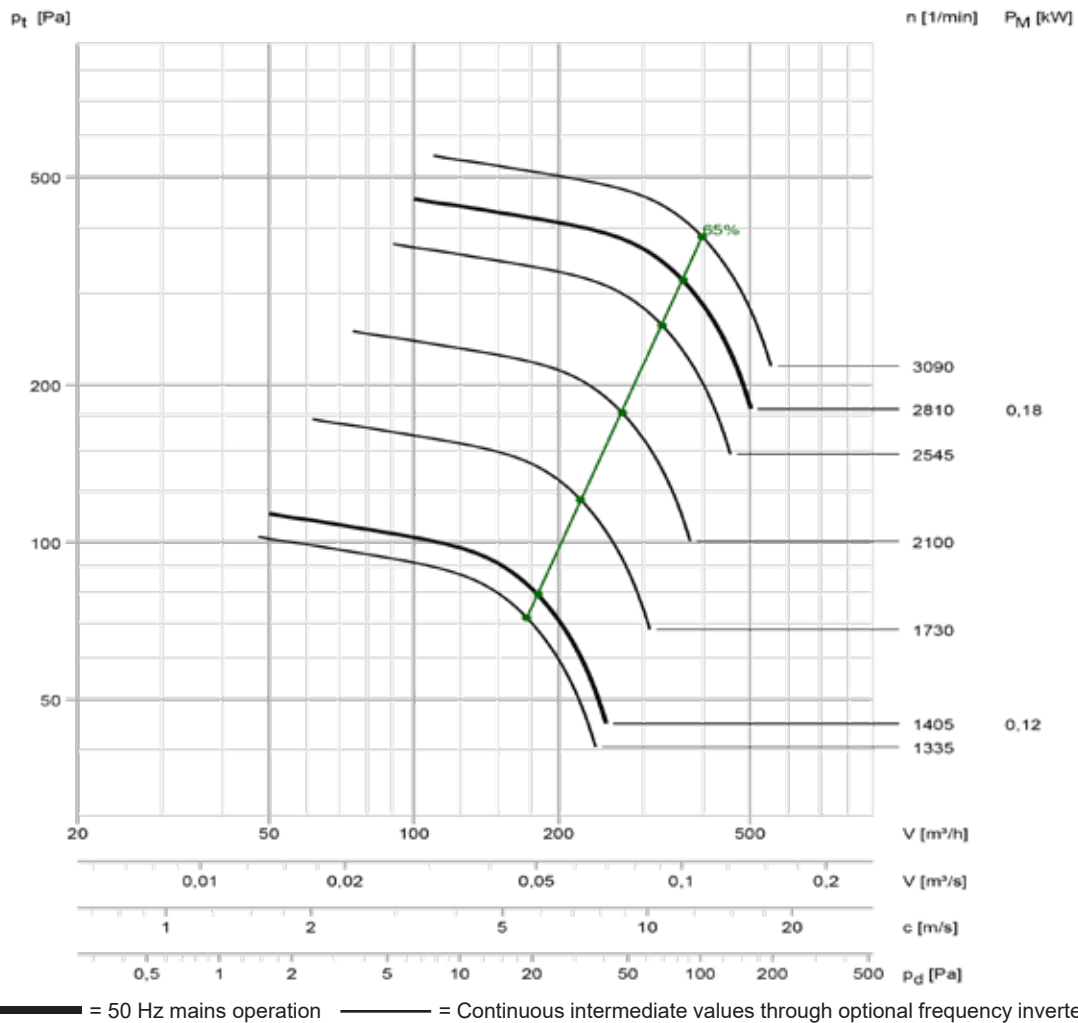

Acoustic level according to VDI 3731									
Speed [1/min]	inlet level / outlet level of the duct sound level non-valuated; Lw3 = Lw4 [dB]								Lp8A (1 m) [dB(A)]
	63	125	250	500	1000	2000	4000	8000	
3090	75	74	83	71	68	64	59	53	65
2810	73	73	81	69	66	62	57	51	63
2545	71	71	79	67	63	59	54	48	61
2100	68	67	75	63	59	55	49	43	47
1730	63	72	60	57	53	49	43	36	50
1405	60	68	56	53	48	43	37	31	45
1335	59	67	55	51	47	42	36	29	44

 Adaptor
P. 66

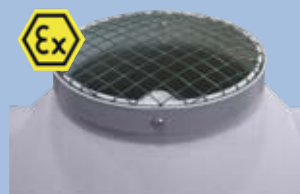
 Shaft seal
felt ring
P. 70

 Protection grid
P. 70

 Fans optionally available
for Ex-Zone!
P. 72

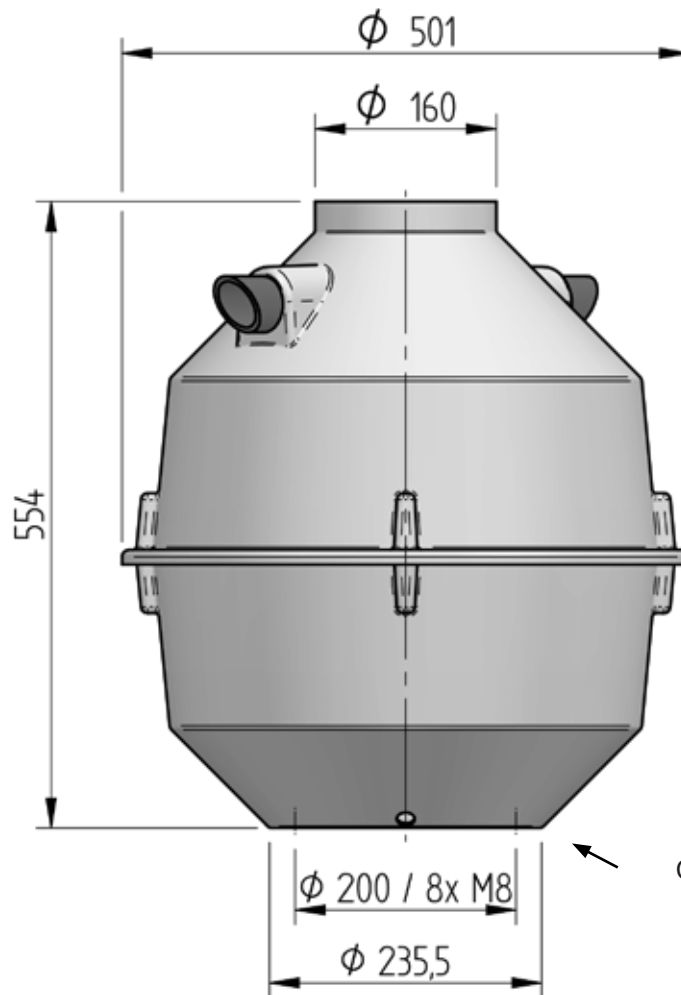
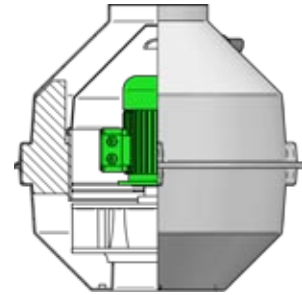
HF - Roof fan
Type series HF D ...-15 / 17 D



Connection diameter: $\phi 160$

Weight: ~ 15 kg

All dimensions in mm.

Accessories:



Roof mounting
DA1 without base
P. 44

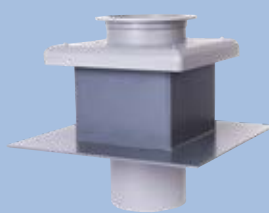

Roof mounting
DA2 with base
P. 46



Silencer for roof fans
P. 52

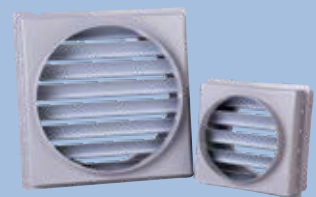

Automatic louver damper
JKS1
P. 64

HF D 160-17 D

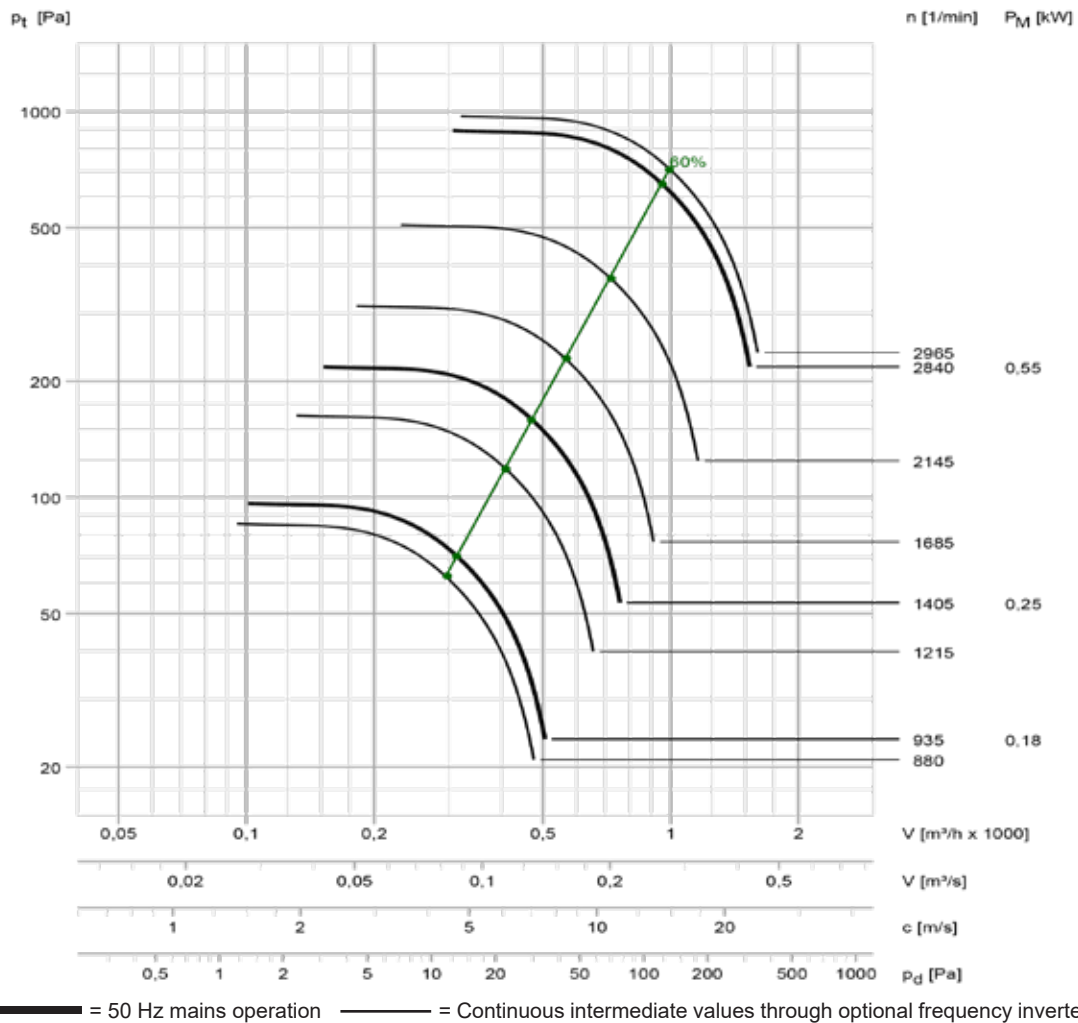

Acoustic level according to VDI 3731									
Speed [1/min]	inlet level / outlet level of the duct sound level non-valuated; Lw3 = Lw4 [dB]								Lp8A (1 m) [dB(A)]
	63	125	250	500	1000	2000	4000	8000	
2965	81	81	89	77	74	70	65	59	72
2840	80	80	89	76	73	69	64	58	71
2145	76	75	83	70	67	62	57	51	65
1685	70	79	67	64	60	55	49	43	57
1405	67	75	63	60	56	51	45	38	53
1215	64	72	60	56	52	47	41	34	49
935	59	67	54	51	46	40	34	26	44
880	66	54	52	48	43	37	31	23	40

 Adaptor
P. 66

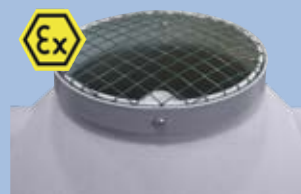
 Shaft seal
felt ring
P. 70

 Protection grid
P. 70

 Fans optionally available
for Ex-Zone!
P. 72

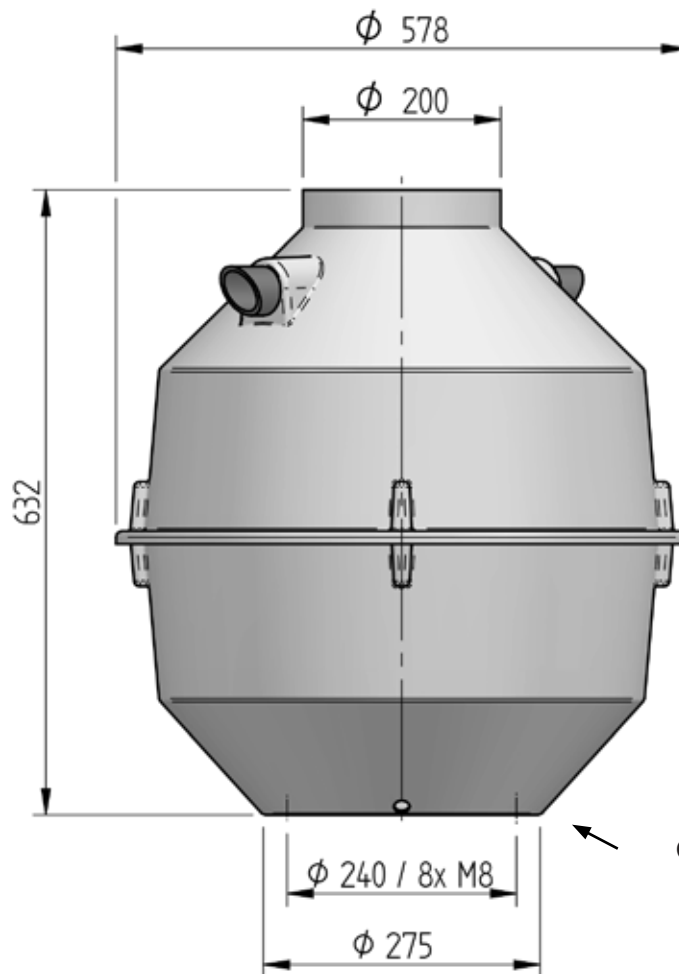
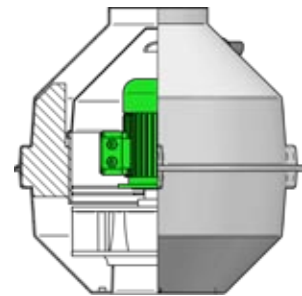
HF - Roof fan
Type series HF D ...-15 / 17 D



Connection diameter: Ø 200

Weight: ~ 17 kg

All dimensions in mm.

Accessories:



Roof mounting
DA1 without base
P. 44

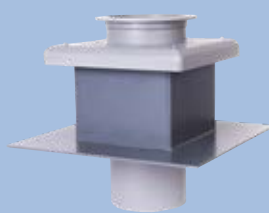

Roof mounting
DA2 with base
P. 46



Silencer for roof fans
P. 52

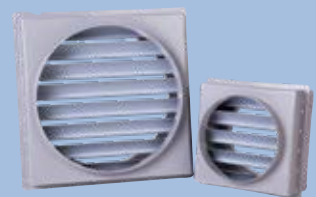

Automatic louver damper
JKS1
P. 64

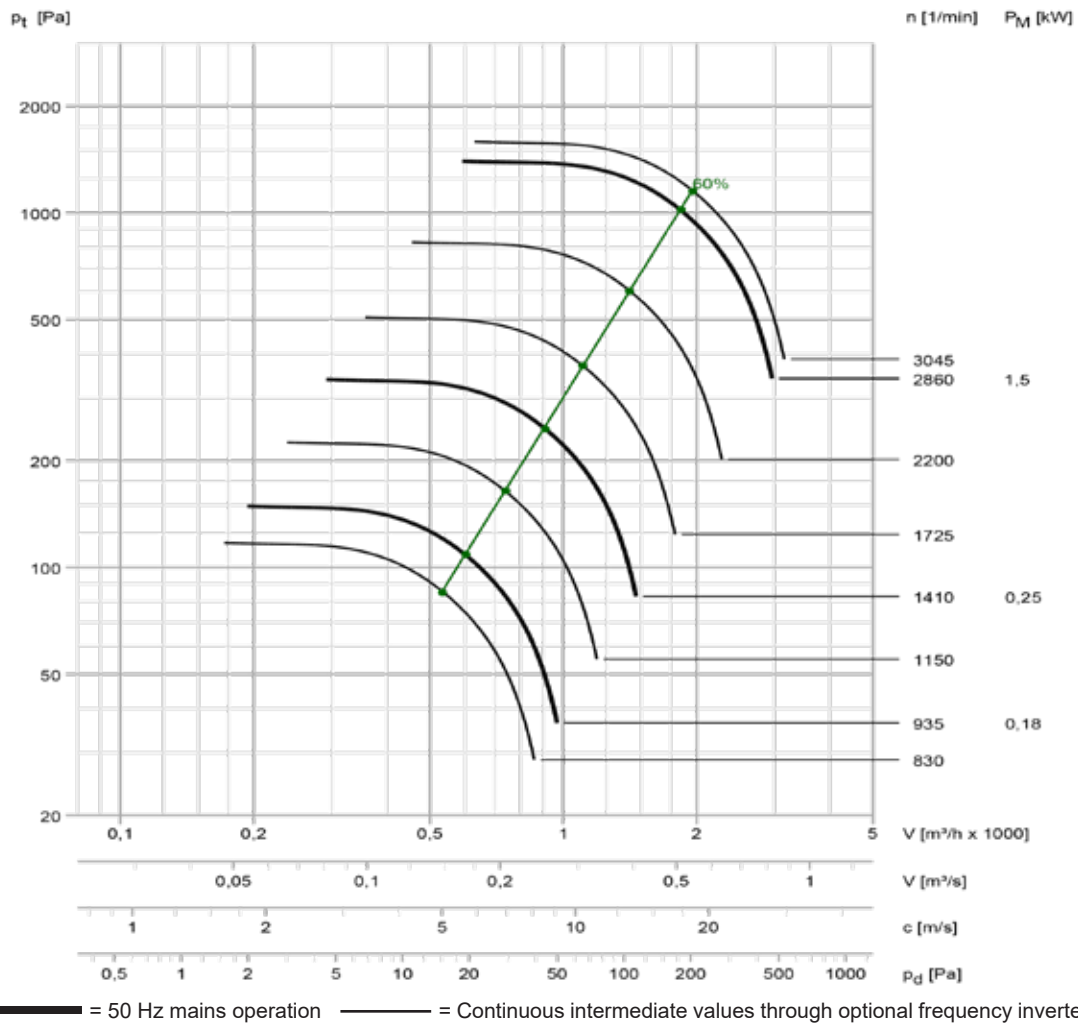

Acoustic level according to VDI 3731									
Speed [1/min]	inlet level / outlet level of the duct sound level non-valuated; Lw3 = Lw4 [dB]								Lp8A (1 m) [dB(A)]
	63	125	250	500	1000	2000	4000	8000	
3045	86	85	94	82	79	75	70	64	78
2860	85	84	93	81	77	73	68	62	76
2200	80	79	88	75	72	67	62	55	71
1725	75	84	71	69	65	60	54	48	62
1410	71	80	67	64	60	55	49	42	57
1150	67	76	63	59	55	50	44	36	53
935	63	71	59	55	50	45	38	31	48
830	70	57	54	51	46	40	33	26	43

 Adaptor
P. 66

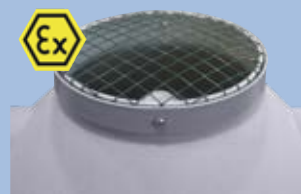
 Shaft seal
felt ring
P. 70

 Protection grid
P. 70

 Fans optionally available
for Ex-Zone!
P. 72

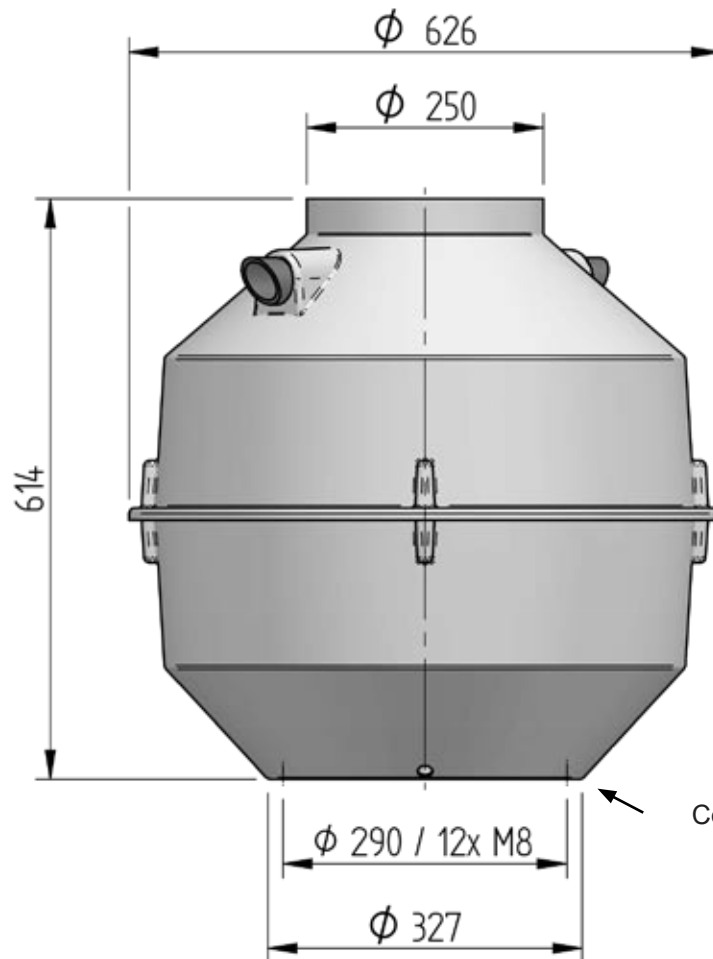
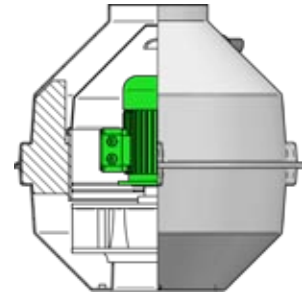
HF - Roof fan
Type series HF D ...-15 / 17 D



Connection diameter: Ø 250

Weight: ~ 24 kg

All dimensions in mm.

Accessories:



Roof mounting
DA1 without base
P. 44

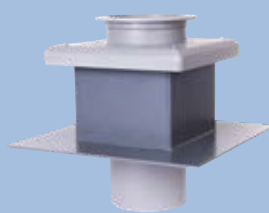

Roof mounting
DA2 with base
P. 46



Silencer for roof fans
P. 52

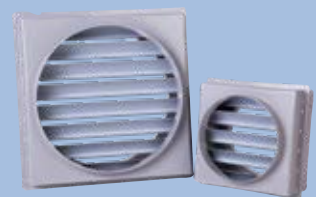

Automatic louver damper
JKS1
P. 64

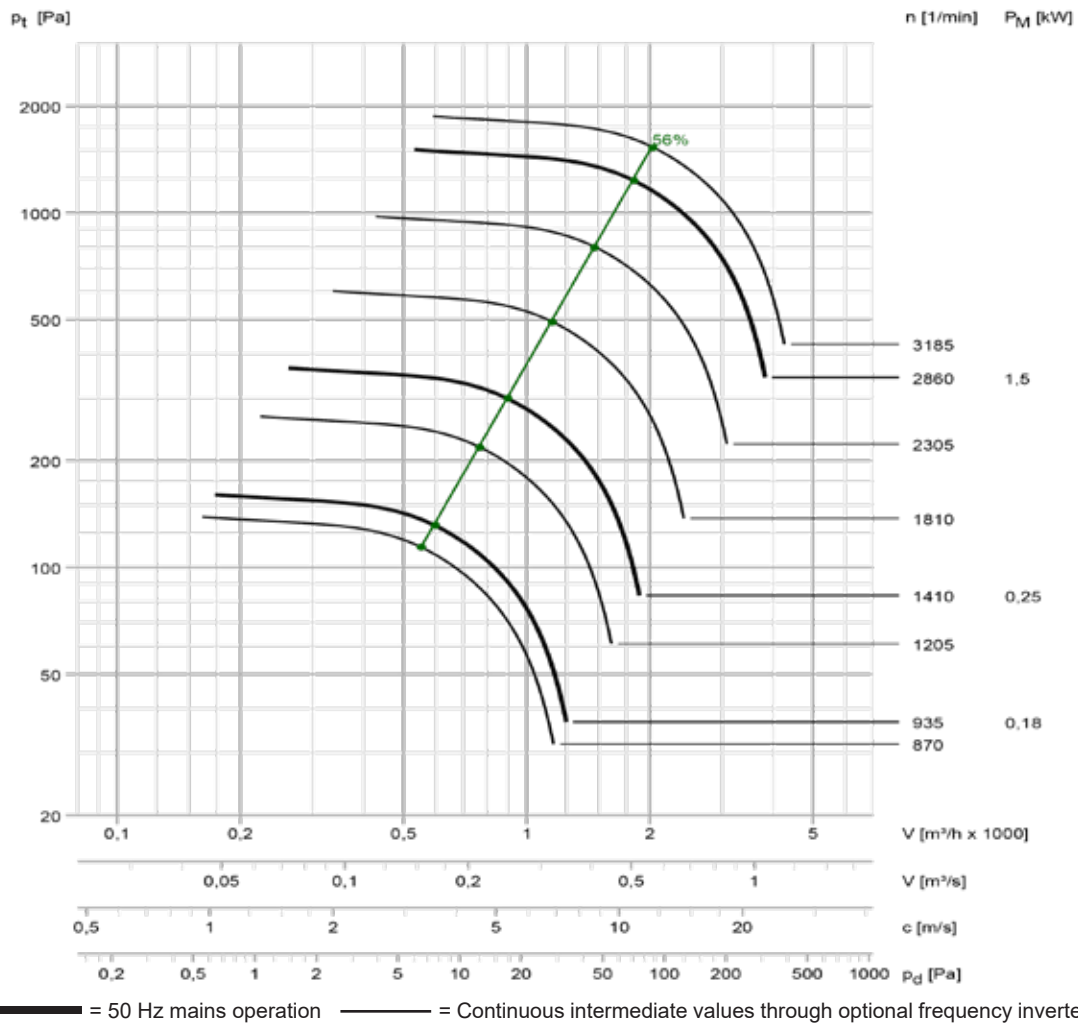

Acoustic level according to VDI 3731									
Speed [1/min]	inlet level / outlet level of the duct sound level non-valuated; Lw3 = Lw4 [dB]								Lp8A (1 m) [dB(A)]
	63	125	250	500	1000	2000	4000	8000	
3185	92	92	100	88	85	81	76	71	84
2860	90	90	99	86	83	79	74	68	82
2305	87	86	95	82	79	74	69	63	78
1810	84	83	91	78	74	69	63	57	74
1410	78	87	74	71	67	62	56	49	65
1205	76	84	71	68	64	58	52	45	62
935	71	79	66	63	58	52	46	39	56
870	78	66	63	60	55	49	43	35	52

 Adaptor
P. 66

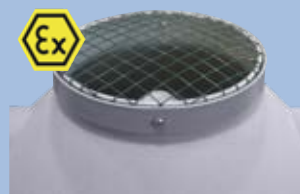
 Shaft seal
felt ring
P. 70

 Protection grid
P. 70

 Fans optionally available
for Ex-Zone!
P. 72

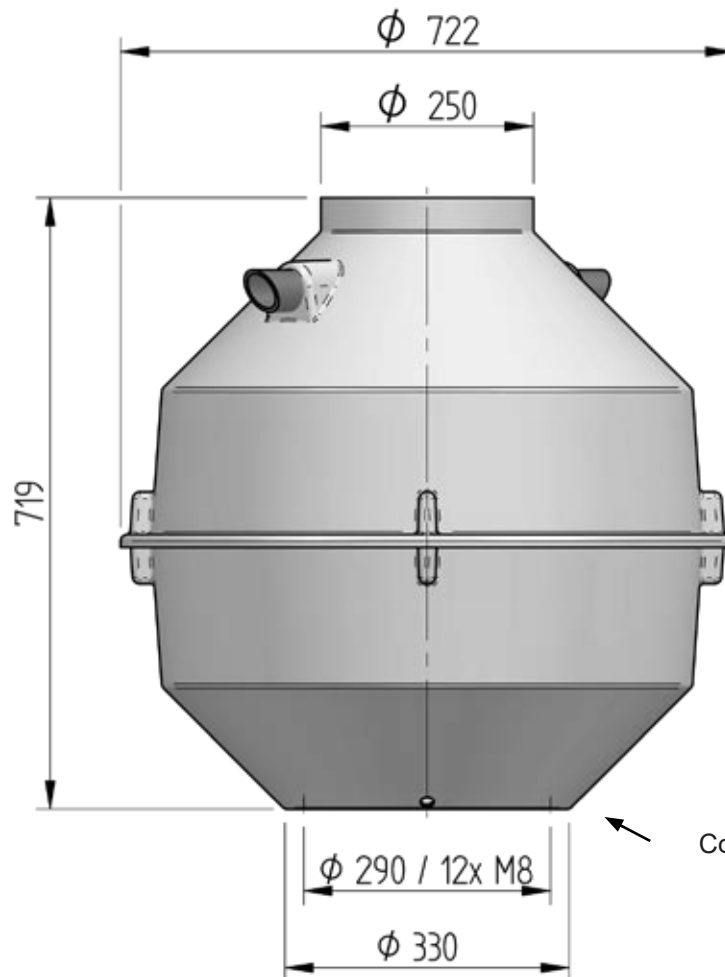
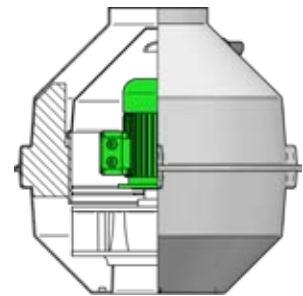
HF - Roof fan
Type series HF D ...-15 / 17 D



Connection diameter: \varnothing 250

Weight: ~ 24 kg

All dimensions in mm.

Accessories:



Roof mounting
DA1 without base
P. 44

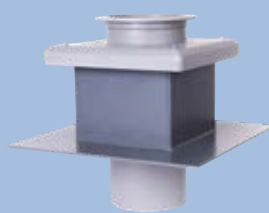

Roof mounting
DA2 with base
P. 46



Silencer for roof fans
P. 52

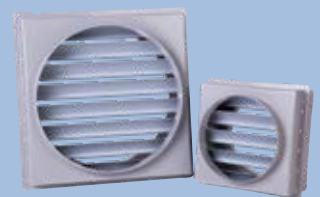

Automatic louver damper
JKS1
P. 64

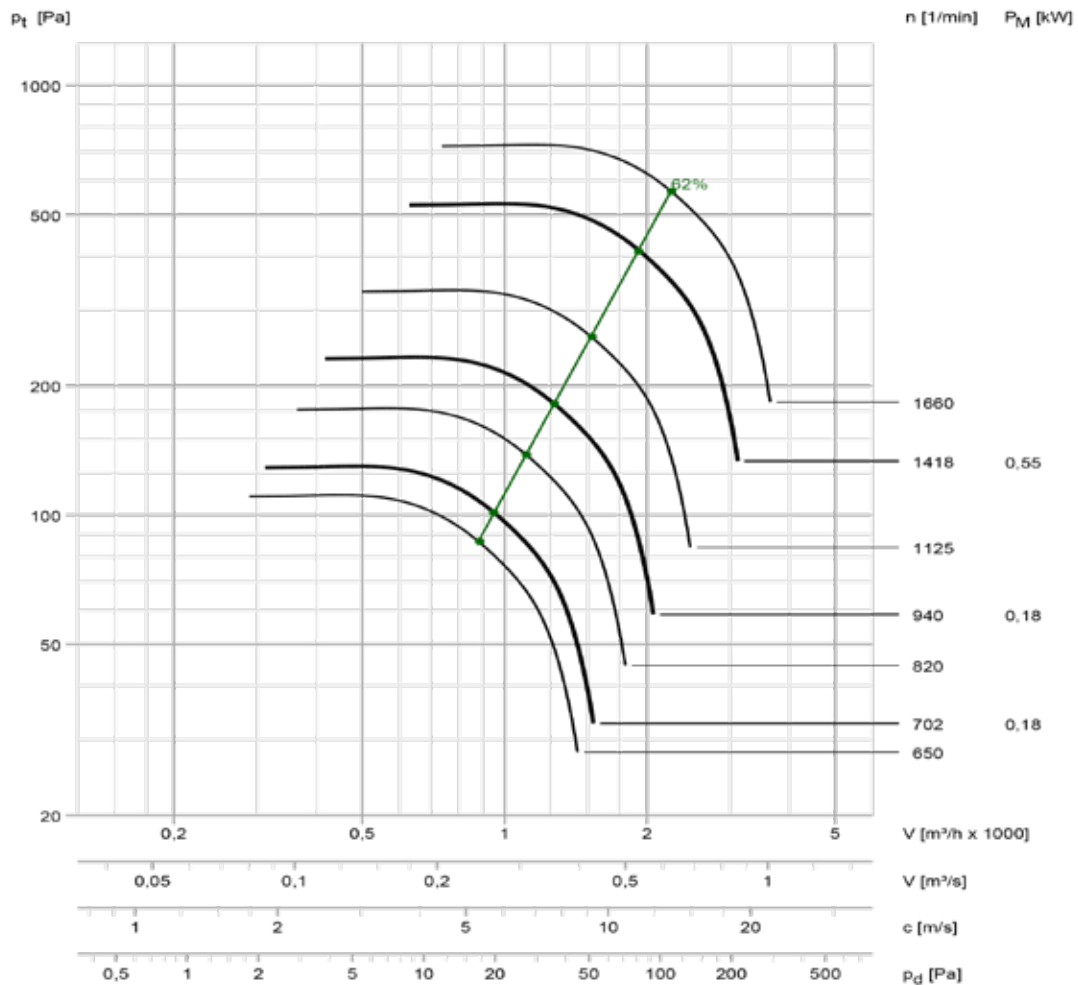

= 50 Hz mains operation
 = Continuous intermediate values through optional frequency inverter

Acoustic level according to VDI 3731									
Speed [1/min]	inlet level / outlet level of the duct sound level non-valuated; Lw3 = Lw4 [dB]								Lp8A (1 m) [dB(A)]
	63	125	250	500	1000	2000	4000	8000	
1660	79	87	75	72	68	63	58	51	66
1418	76	84	72	69	65	60	54	47	62
1125	71	80	67	64	59	54	48	40	57
940	68	76	63	60	55	49	43	35	53
820	74	62	59	55	50	44	38	30	48
702	71	59	55	51	46	40	33	26	44
650	69	57	54	49	44	38	31	23	42



Adaptor
P. 66



Shaft seal
felt ring
P. 70

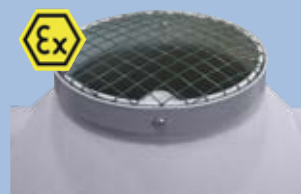

Protection grid
P. 70



Fans optionally available
for Ex-Zone!
P. 72

HF - Roof fan
Type series HF D ...-15 / 17 D

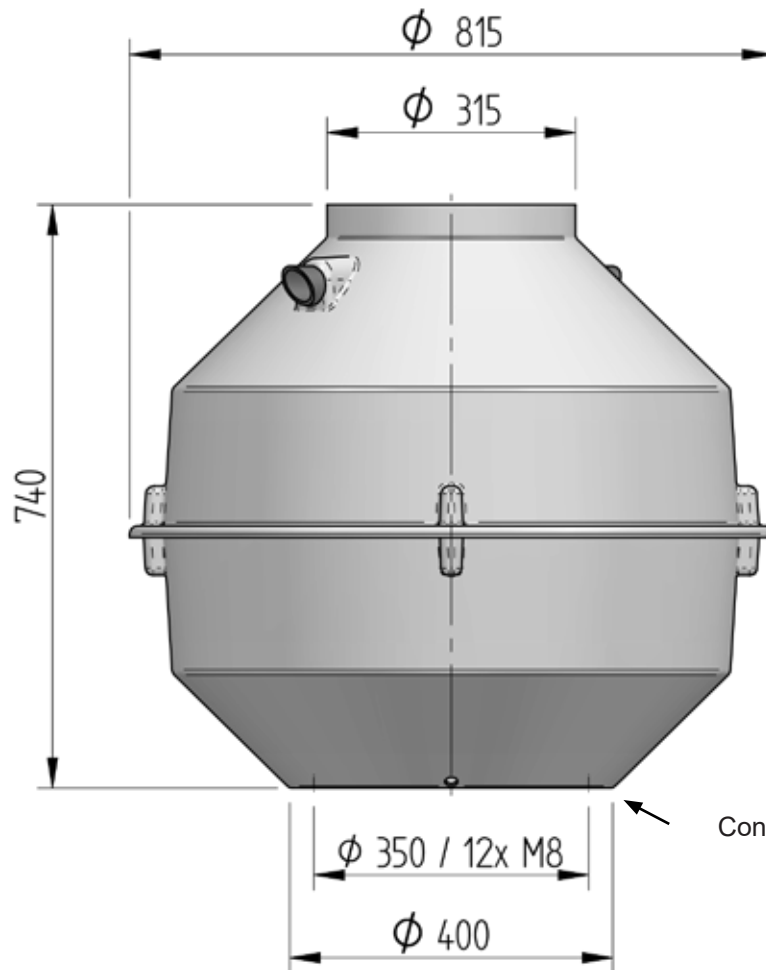
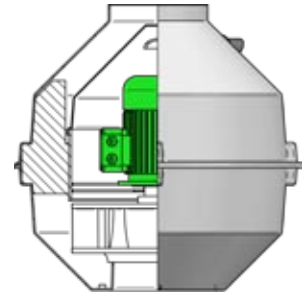

Connection diameter: \varnothing 315

Weight: ~ 43 kg

All dimensions in mm.

Accessories:



Roof mounting
DA1 without base
P. 44

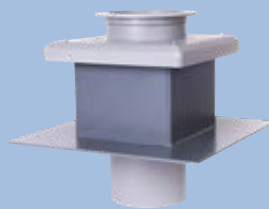

Roof mounting
DA2 with base
P. 46



Silencer for roof fans
P. 52

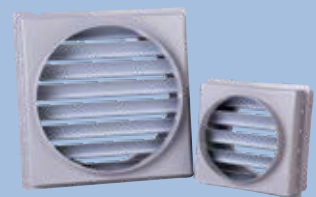

Automatic louver damper
JKS1
P. 64

HF D 315-15 D

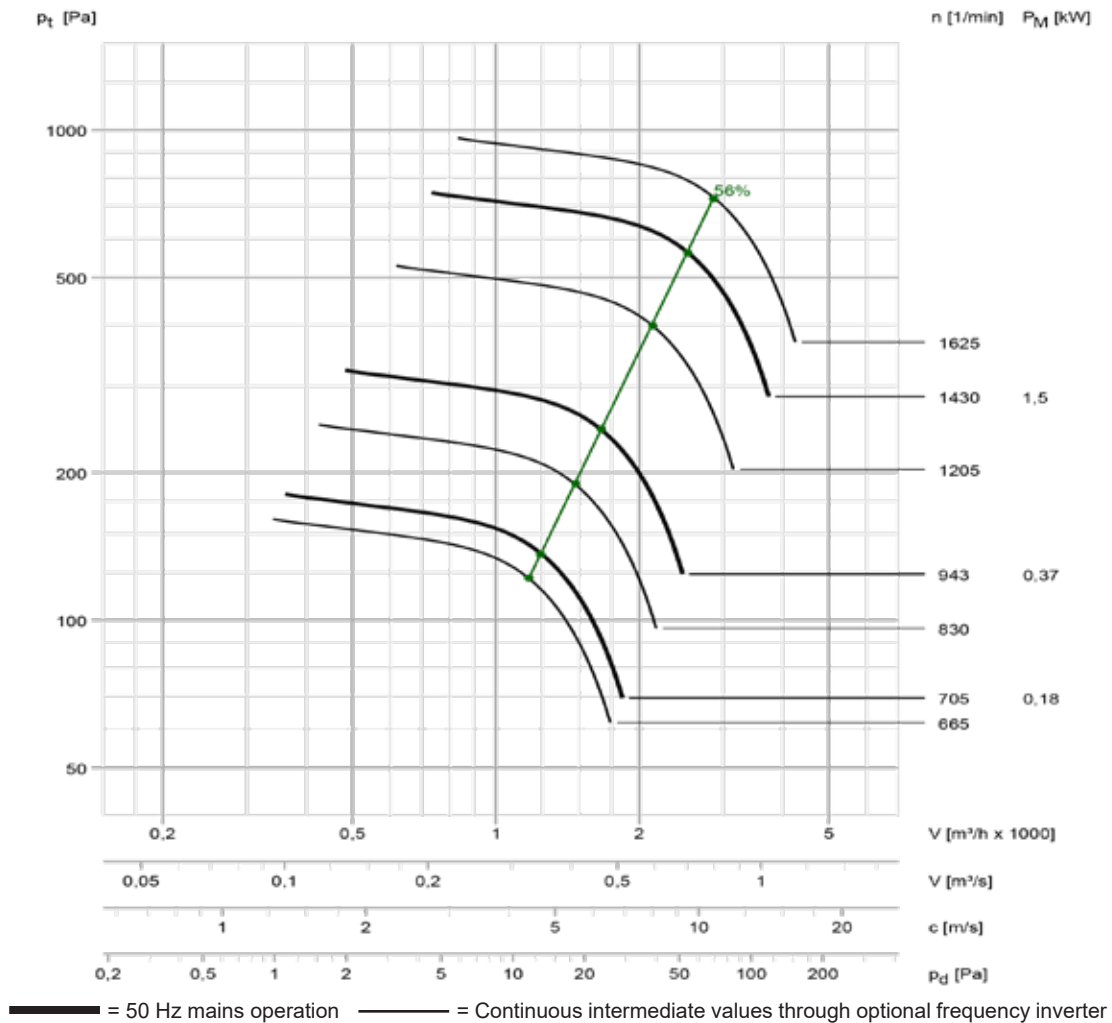

Acoustic level according to VDI 3731									
Speed [1/min]	inlet level / outlet level of the duct sound level non-valuated; Lw3 = Lw4 [dB]								Lp8A (1 m) [dB(A)]
	63	125	250	500	1000	2000	4000	8000	
1625	86	95	83	80	76	71	66	59	74
1430	84	93	81	78	73	68	62	56	71
1205	82	90	77	74	70	64	58	51	68
943	77	86	73	69	64	59	52	45	63
830	84	72	69	65	60	54	48	40	58
705	81	68	65	61	56	50	43	35	54
665	80	67	64	60	55	49	42	34	53

 Adaptor
P. 66

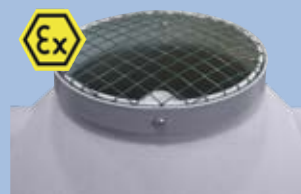
 Shaft seal
felt ring
P. 70

 Protection grid
P. 70

 Fans optionally available
for Ex-Zone!
P. 72

HF - Roof fans Type series HF D ...-16 D



Advantages

- Weatherproof design
- Reliable drainage of rainwater
- Compact design
- Easy installation on flange
- Wide range of accessories available

Application

- Ideal for the extraction of corrosive gases
- Extraction of potentially explosive atmosphere

Design

- Internal motors separated from the air flow
- No metal parts in the air flow
- Shaft gap fitted as standard with seal
- Fitted as standard with repair switch or explosion-proof terminal box
- Available in many materials (PPs, PPs-el, PVC, ...)
- Use of explosion-proof motors possible



Suction side of the fan with threaded bushings for flange mounting

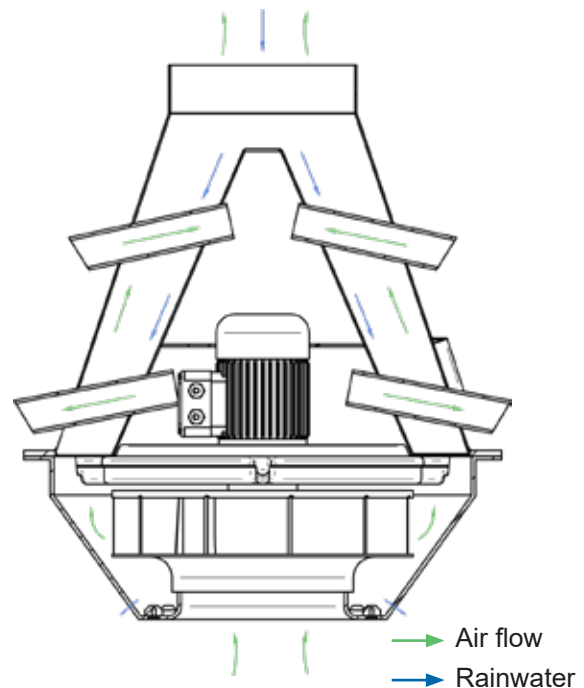

Accessories:



Roof mounting
DA1 without base
P. 44

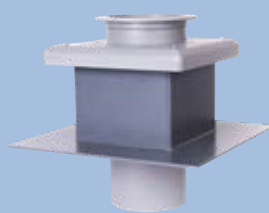

Roof mounting
DA2 with base
P. 46



Silencer for roof fans
P. 52

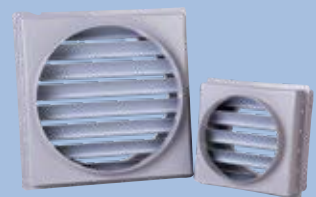

Automatic louver damper
JKS1
P. 64

Specification

HF - Roof fan

Corrosion resistant plastic radial roof fan with housing in thermoplastics, in stable, deep-drawn version, one inlet side, splinter protection according to accident prevention rules as plastic coated wire mesh. In case of upright mounting the exhaust air is blown out vertical according to requirements for aggressive air. All parts exposed to exhaust air are made of plastic or encapsulated by plastic. Shaft passage brought to minimum clearance using felt ring seal. Impeller with backward curved blades, floating-mounted on the motor shaft, statically and dynamically balanced, quality of balancing at least G 6.3 (DIN ISO 21940-11). Including internally mounted motor, encapsulated against the delivery medium, and outside mounted repair switch in case of standard motors (without ex-protection) respectively externally mounted terminal box for ex-motors. External ventilation for the motor via outward located ducts.

Manufacturer	: Hürner Luft- und Umwelttechnik	
Type	: HF D ... - 16 D	
Housing-material	: PPs	
Impeller-material	: PPs	
Inlet diameter	: ...	mm
Medium	: exhaust air	
Volume flow	: ...	m ³ /h
Total pressure difference	: ...	Pa
Static pressure difference	: ...	Pa
Sound pressure level Lp8A (1 m)	: ...	dB(A)
SFP	: ...	W/(m ³ /s)
Motor power	: ...	kW
Voltage	: 400	V
Frequency	: 50	Hz
Rated current	: ...	A
Enclosure / motor protection	: IP 55 / PTC	



Adaptor
P. 66



Protection grid
P. 70

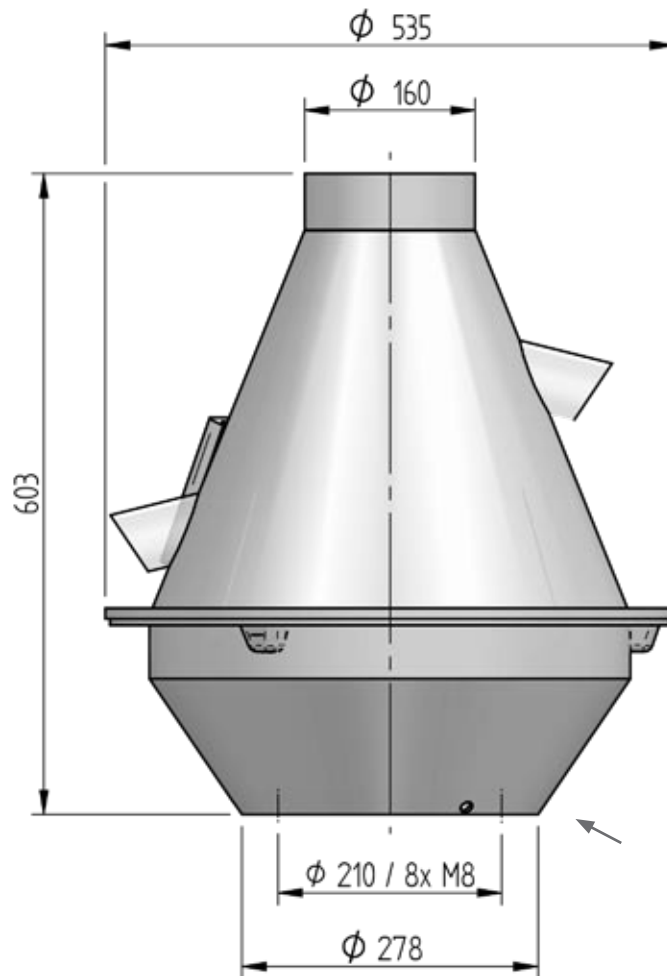
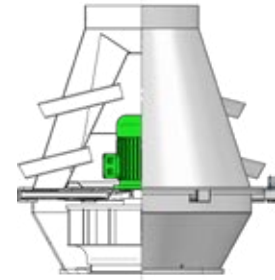

Fans optionally available
for Ex-Zone!
P. 72

HF - Roof fan
 Type series HF D ...-16 D

 Connection diameter: ϕ 160

Weight: ~ 29 kg

All dimensions in mm.

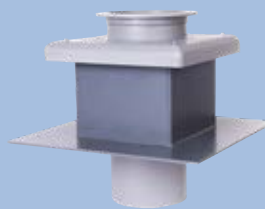
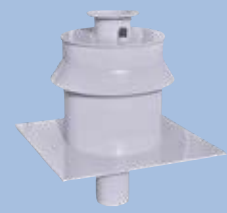
Accessories for ATEX Zone 1 made of PPs-el:

 Roof mounting
 DA1 without base
 P. 44

 Roof mounting
 DA2 with base
 P. 46

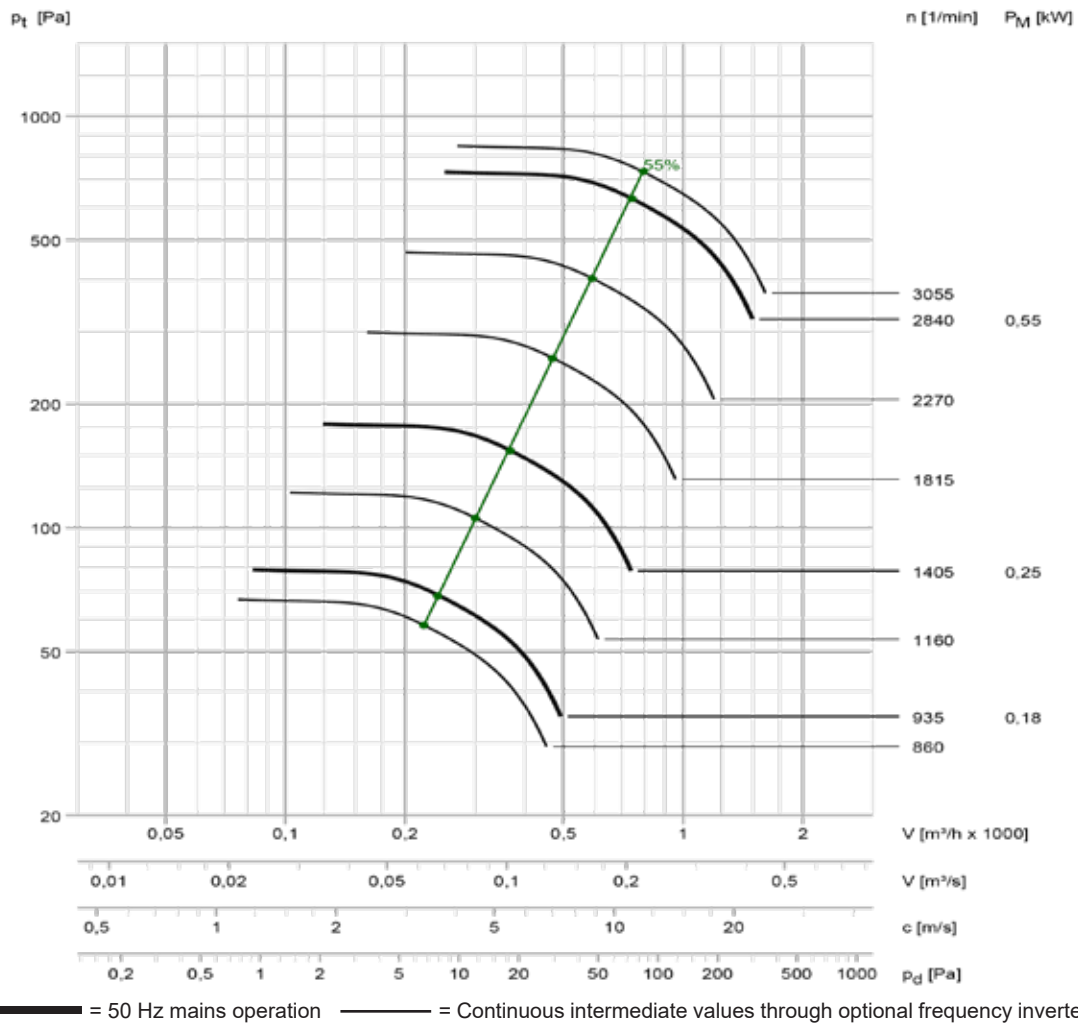
 Silencer for roof fans
 P. 52

HF D 160-16 D only for ATEX Zone 1



Acoustic level according to VDI 3731									
Speed [1/min]	inlet level / outlet level of the duct sound level non-valuated; Lw3 = Lw4 [dB]								Lp8A (1 m) [dB(A)]
	63	125	250	500	1000	2000	4000	8000	
3055	85	85	84	91	78	74	69	63	80
2840	84	84	82	90	77	73	68	62	78
2270	81	80	78	86	72	68	63	56	74
1815	76	75	83	70	66	61	56	49	65
1405	72	70	78	65	61	56	50	43	60
1160	69	67	74	61	57	51	45	38	56
935	63	71	58	55	50	44	38	31	48
860	62	70	57	53	48	42	36	28	46



Adaptor
P. 66

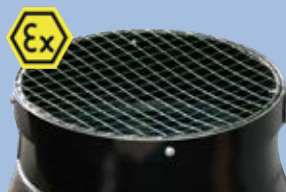

Protection grid
P. 70

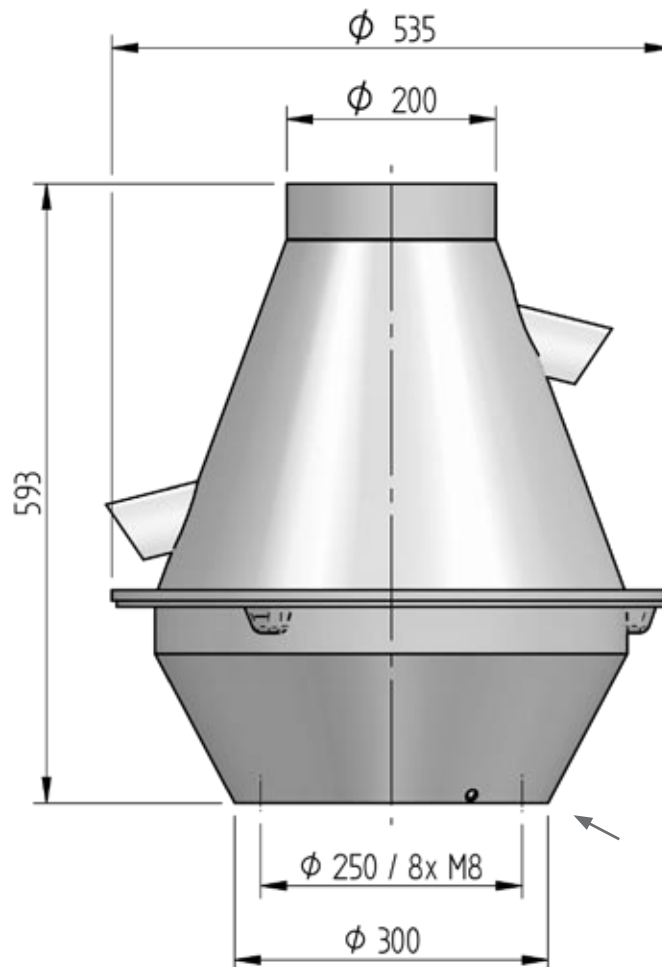
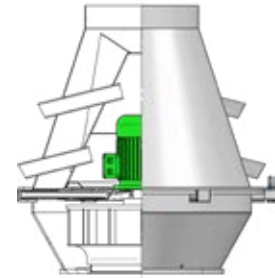

Fans optionally available
for Ex-Zone!
P. 72

HF - Roof fan
 Type series HF D ...-16 D

 Connection diameter: $\phi 200$

Weight: ~ 35 kg

All dimensions in mm.

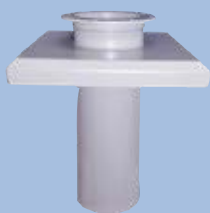
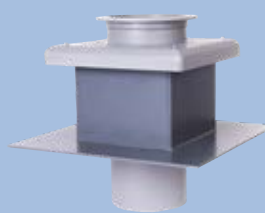
Accessories for ATEX Zone 1 made of PPs-el:

 Roof mounting
 DA1 without base
 P. 44

 Roof mounting
 DA2 with base
 P. 46

 Silencer for roof fans
 P. 52

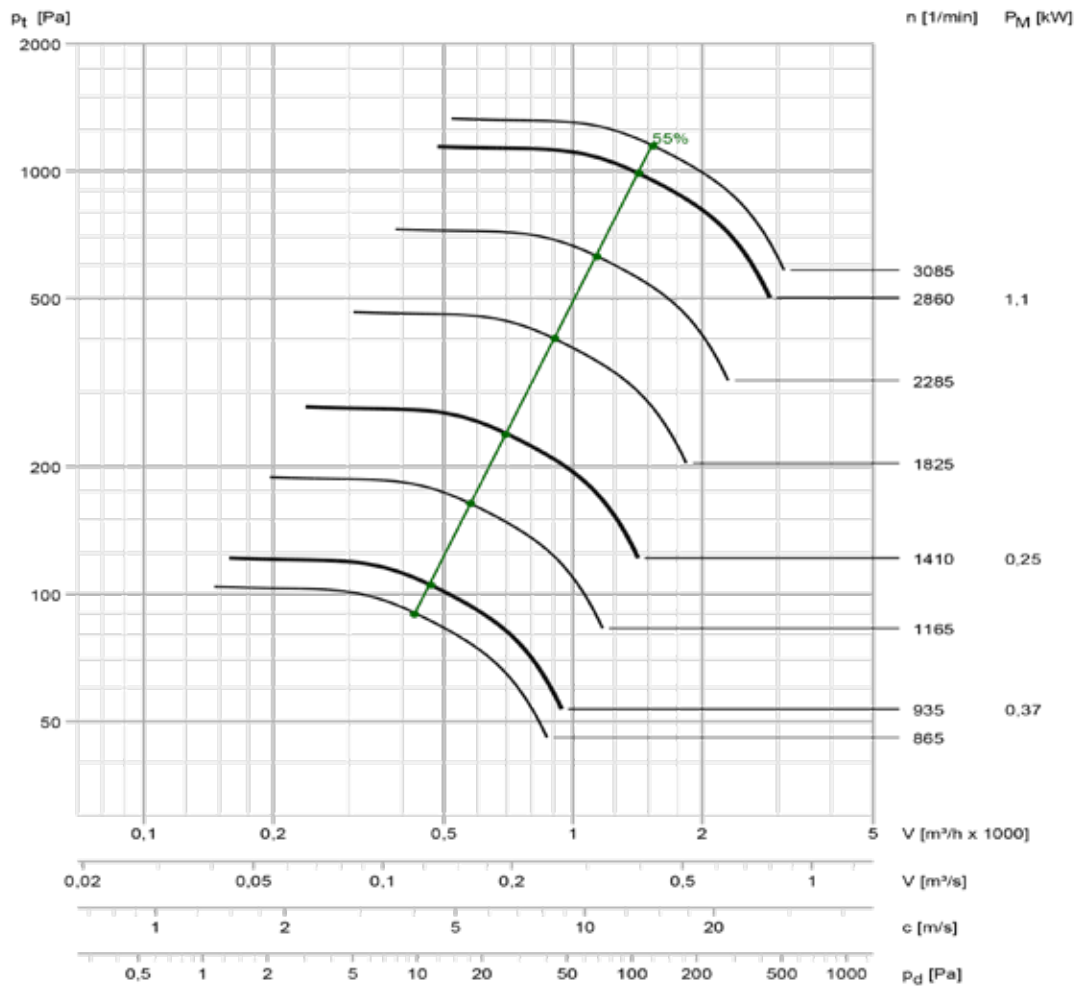
HF D 200-16 D only for ATEX Zone 1



= 50 Hz mains operation
 = Continuous intermediate values through optional frequency inverter

Acoustic level according to VDI 3731									
Speed [1/min]	inlet level / outlet level of the duct sound level non-valuated; Lw3 = Lw4 [dB]								Lp8A (1 m) [dB(A)]
	63	125	250	500	1000	2000	4000	8000	
3085	89	89	87	95	82	78	73	67	84
2860	88	88	86	94	81	77	72	66	83
2285	85	84	82	90	76	72	66	60	78
1825	80	79	87	74	70	65	60	53	70
1410	76	74	82	69	65	60	54	47	64
1165	73	71	78	65	60	55	49	42	61
935	67	75	62	59	54	48	42	34	52
865	66	74	61	57	52	46	40	32	50



Adaptor
P. 66

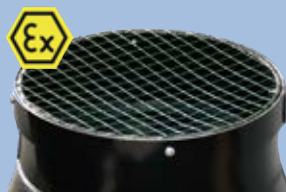

Protection grid
P. 70

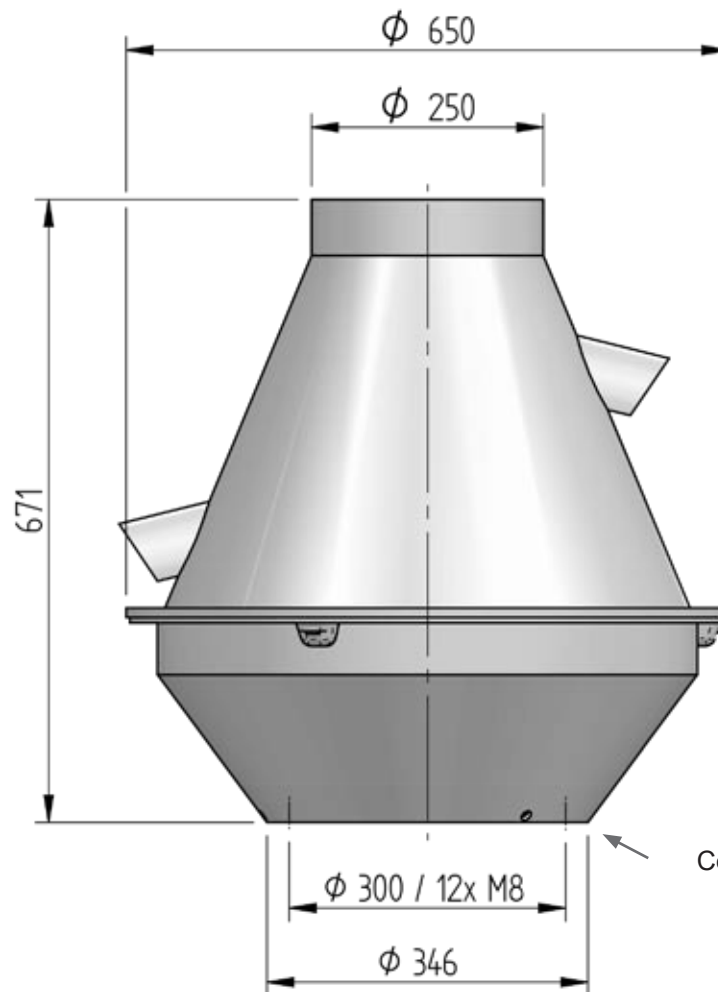
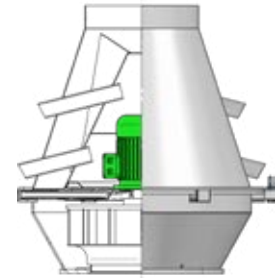

Fans optionally available
for Ex-Zone!
P. 72

HF - Roof fan
 Type series HF D ...-16 D

 Connection diameter: $\phi 250$

Weight: ~ 38 kg

All dimensions in mm.

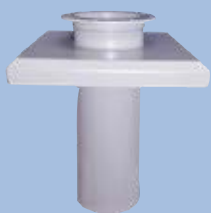
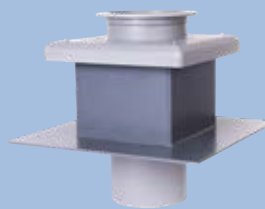
Accessories for ATEX Zone 1 made of PPs-el:

 Roof mounting
 DA1 without base
 P. 44

 Roof mounting
 DA2 with base
 P. 46

 Silencer for roof fans
 P. 52

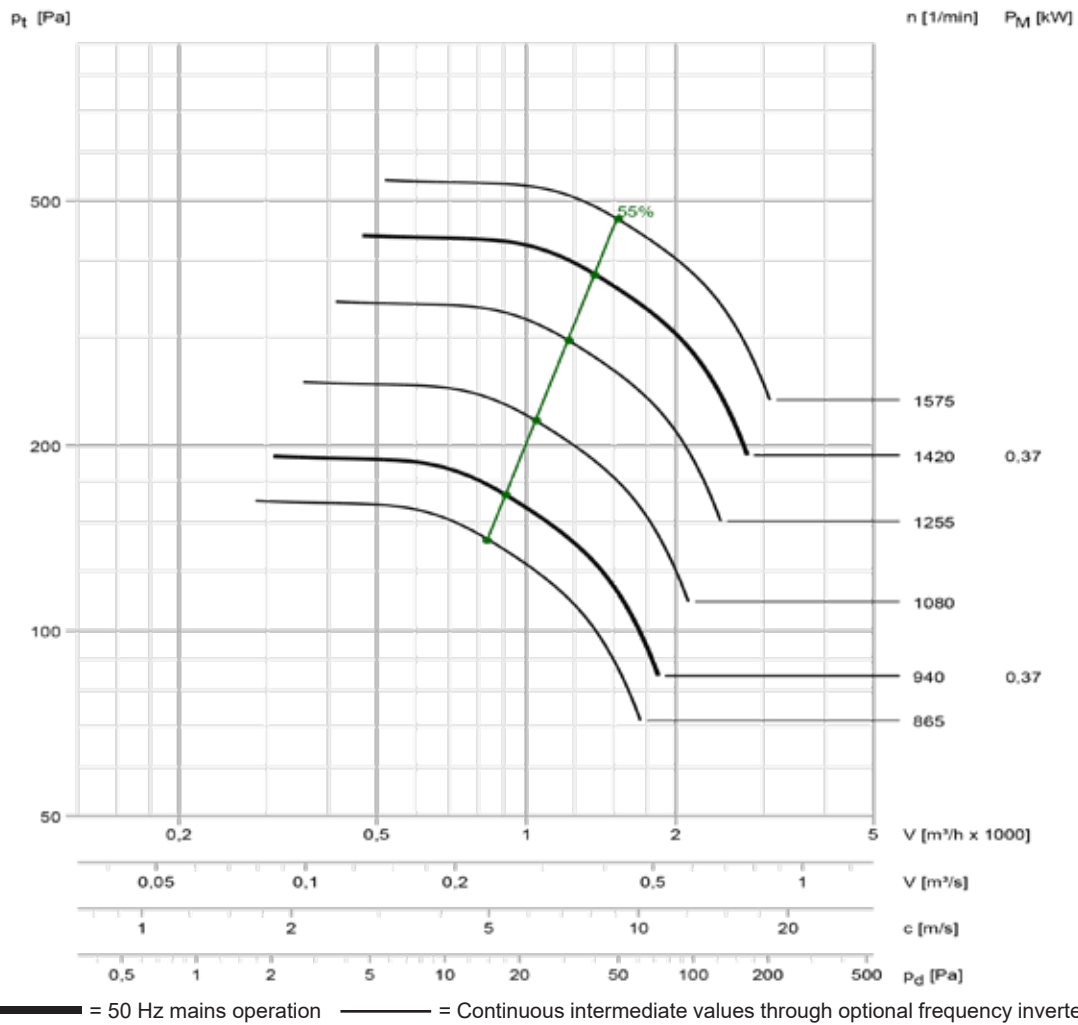
HF D 250-16 D only for ATEX Zone 1



Acoustic level according to VDI 3731									
Speed [1/min]	inlet level / outlet level of the duct sound level non-valuated; Lw3 = Lw4 [dB]								Lp8A (1 m) [dB(A)]
	63	125	250	500	1000	2000	4000	8000	
1575	81	80	88	75	71	66	60	53	71
1420	80	78	86	73	69	64	58	51	69
1255	78	76	84	70	66	61	55	48	67
1080	75	74	81	67	63	57	51	44	64
940	71	79	66	63	58	52	46	39	56
865	70	78	65	61	56	50	44	36	55



Adaptor
P. 66

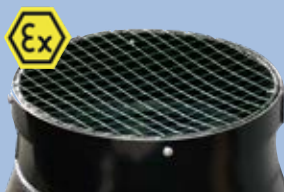

Protection grid
P. 70



Fans optionally available
for Ex-Zone!
P. 72

HF - Roof fan
Type series HF D ...-16 D

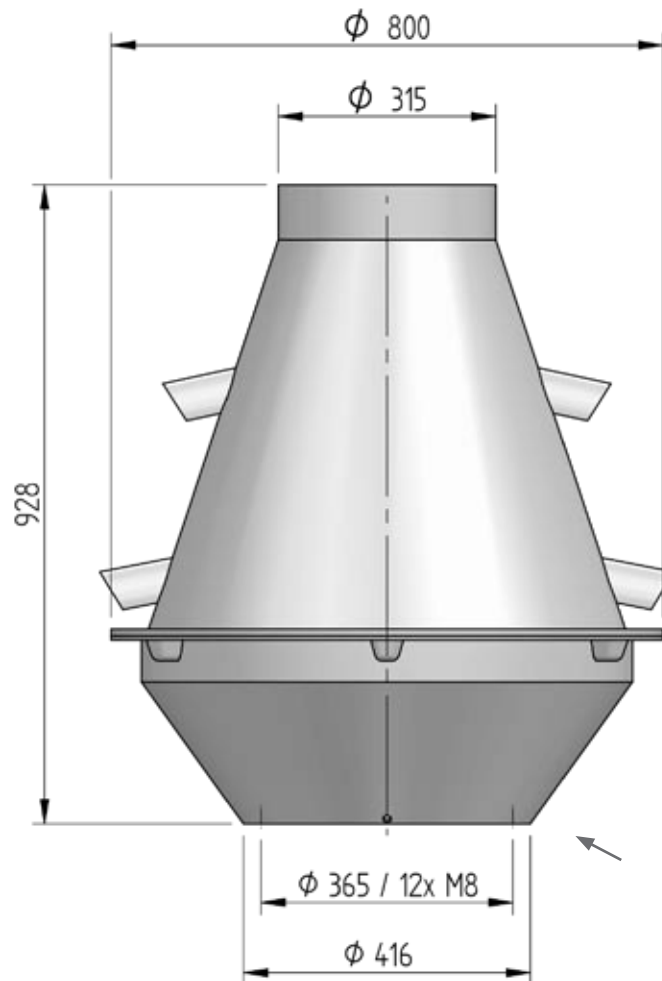
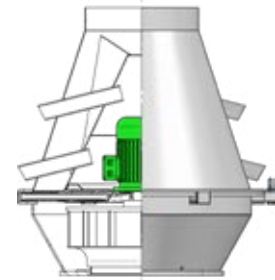

Connection diameter: ϕ 315

Weight: ~ 66 kg

All dimensions in mm.

Accessories:



Roof mounting
DA1 without base
P. 44

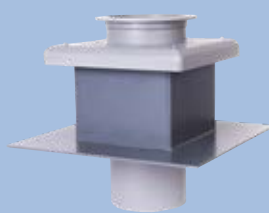

Roof mounting
DA2 with base
P. 46



Silencer for roof fans
P. 52

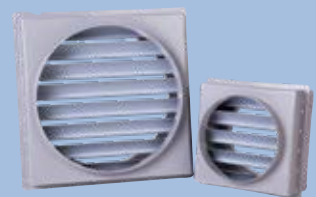

Automatic louver damper
JKS1
P. 64

HF - Roof fan
Type series HF D ...-16 D

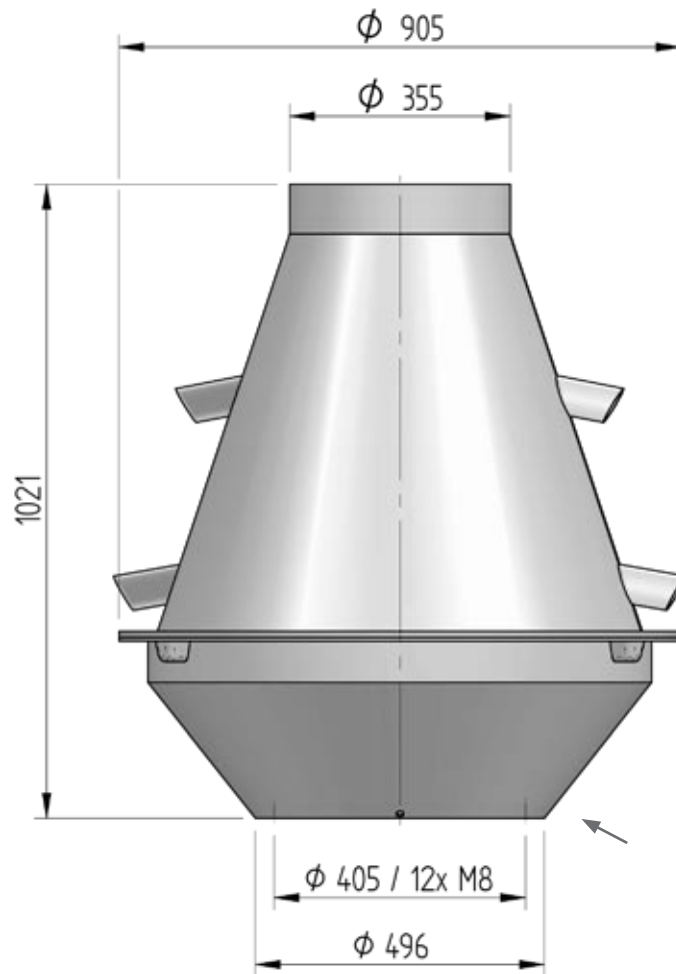
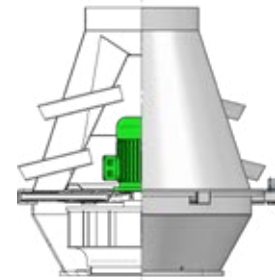

Connection diameter: \varnothing 355

Weight: ~ 84 kg

All dimensions in mm.

Accessories:

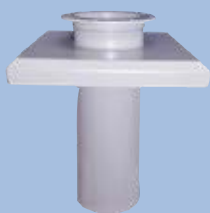

Roof mounting
DA1 without base
P. 44

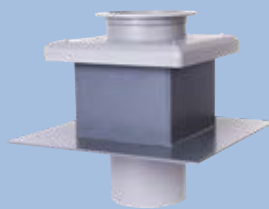

Roof mounting
DA2 with base
P. 46



Silencer for roof fans
P. 52

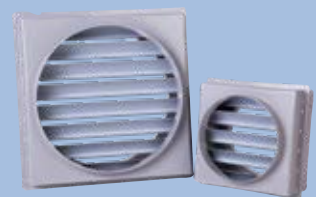

Automatic louver damper
JKS1
P. 64

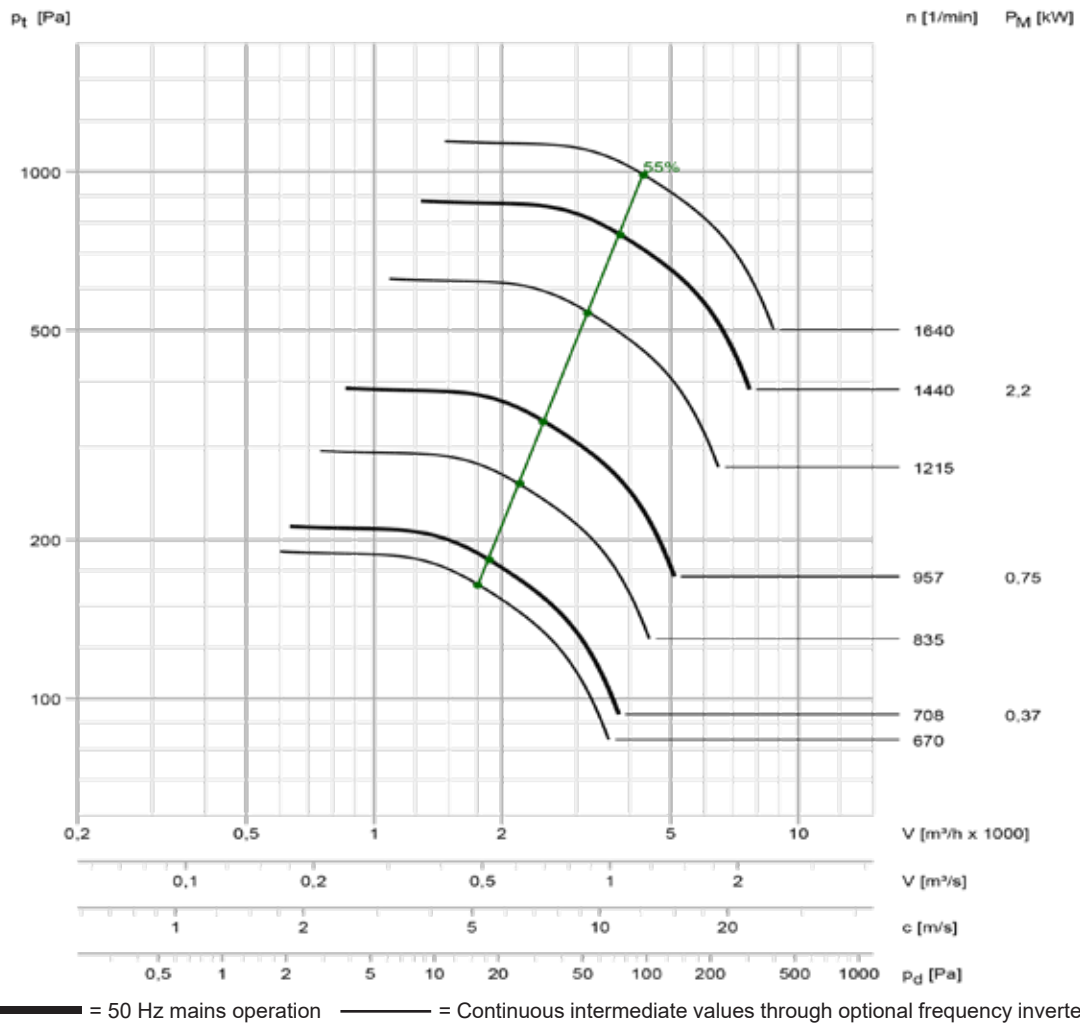

Acoustic level according to VDI 3731									
Speed [1/min]	inlet level / outlet level of the duct sound level non-valuated; Lw3 = Lw4 [dB]								Lp8A (1 m) [dB(A)]
	63	125	250	500	1000	2000	4000	8000	
1640	88	87	94	81	78	73	67	60	78
1440	86	84	92	79	75	70	64	57	76
1215	83	81	89	76	71	66	60	53	73
975	77	85	73	69	64	59	52	45	63
835	75	83	70	66	61	55	49	41	60
708	72	80	67	63	57	52	45	37	57
670	71	79	66	61	56	50	43	35	56



Adaptor
P. 66



Protection grid
P. 70



Fans optionally available
for Ex-Zone!
P. 72

HF - Roof fan
Type series HF D ...-16 D

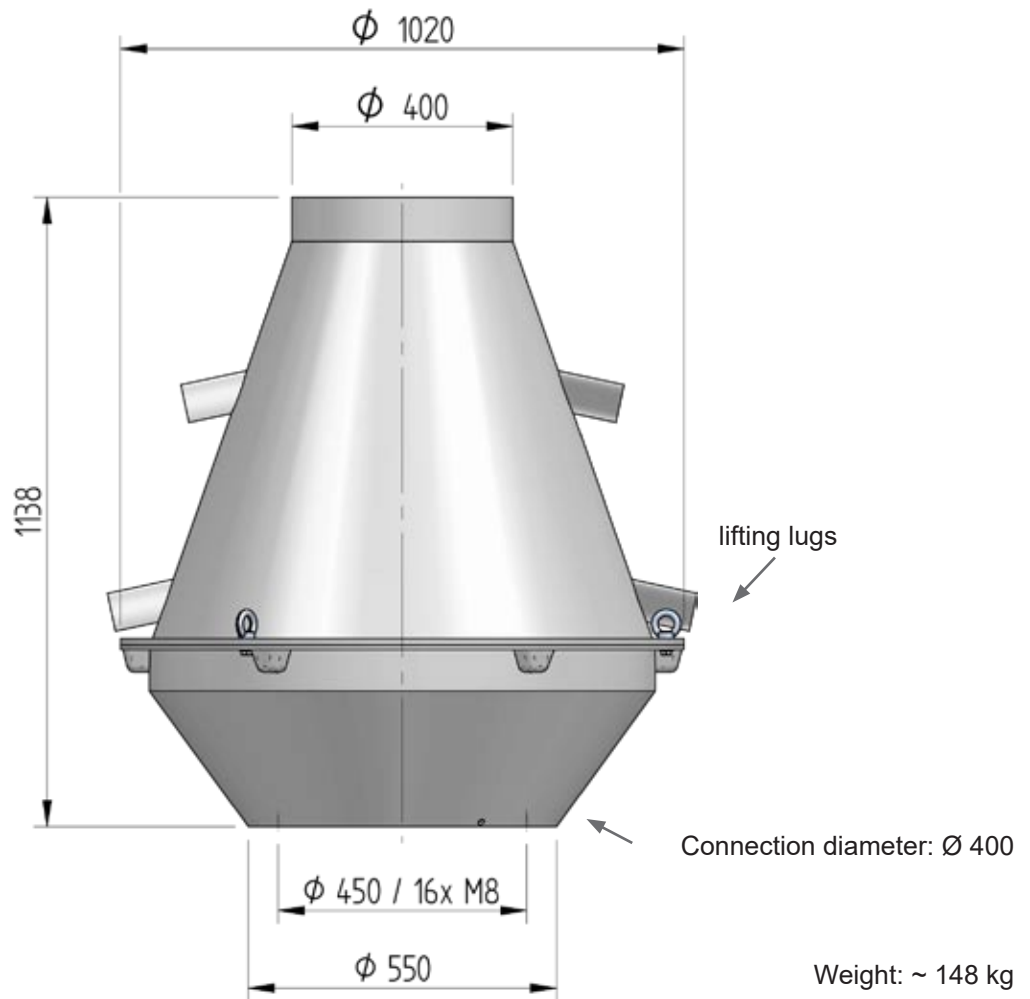
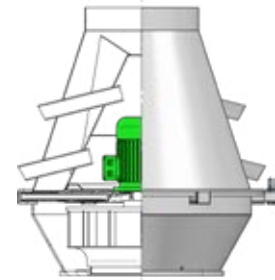

Weight: ~ 148 kg

All dimensions in mm.

Accessories:



Roof mounting
DA1 without base
P. 44

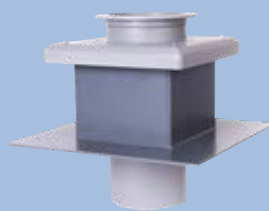

Roof mounting
DA2 with base
P. 46



Silencer for roof fans
P. 52

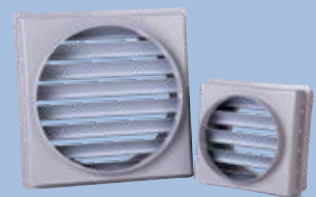

Automatic louver damper
JKS1
P. 64

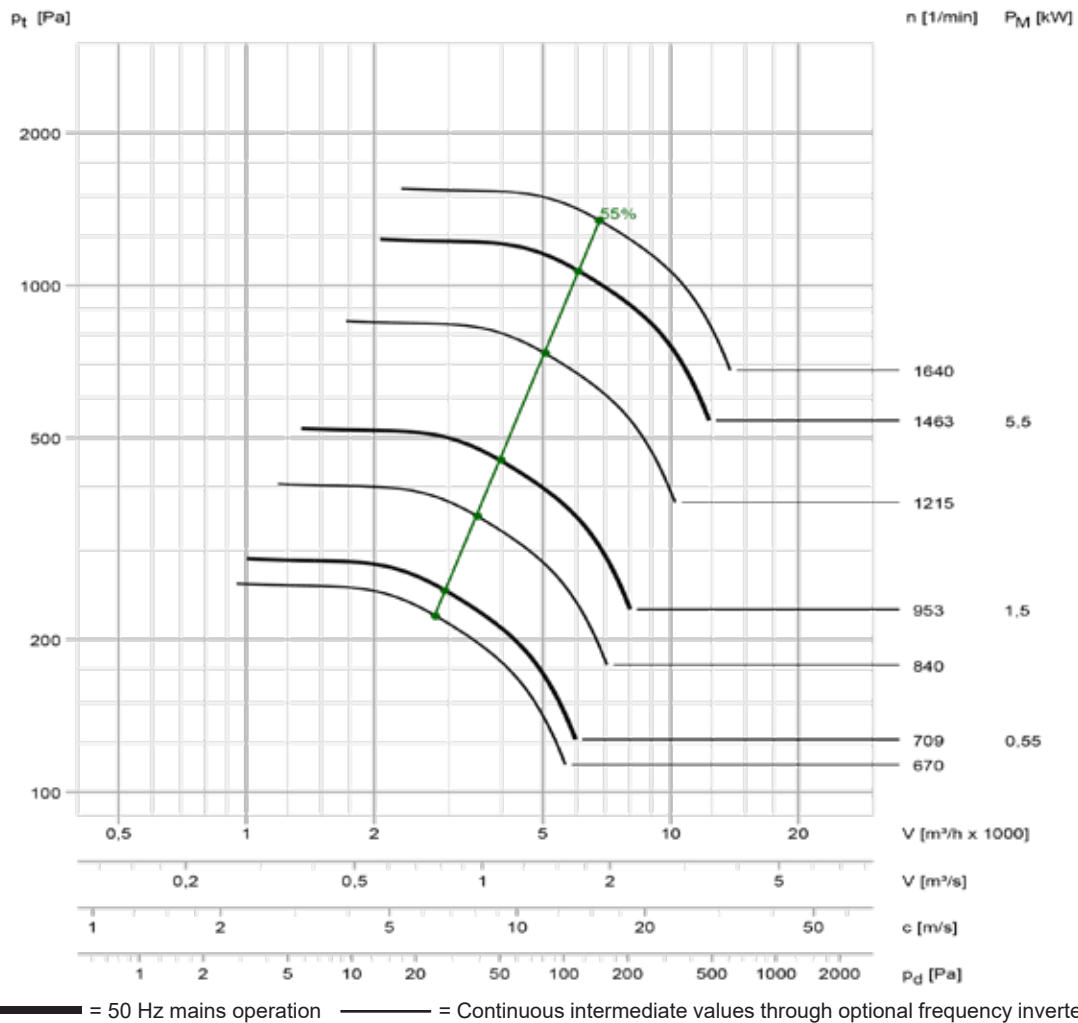

Acoustic level according to VDI 3731									
Speed [1/min]	inlet level / outlet level of the duct sound level non-valuated; $L_{w3} = L_{w4}$ [dB]								Lp8A (1 m) [dB(A)]
	63	125	250	500	1000	2000	4000	8000	
1640	90	89	97	84	80	75	70	63	81
1463	89	87	95	82	78	73	67	60	79
1215	86	84	92	78	74	69	63	56	75
953	80	88	75	72	67	61	55	48	66
840	78	86	73	69	64	58	52	44	63
709	75	83	69	65	60	54	47	40	60
670	74	82	68	64	59	53	46	38	59

 Adaptor
P. 66

 Protection grid
P. 70

 Fans optionally available
for Ex-Zone!
P. 72

HF - Roof fans Type series HF D ...-13 D

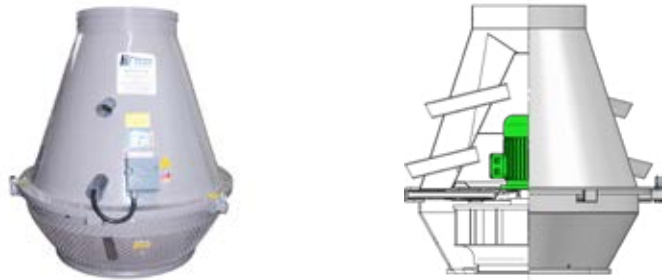

Advantages

- Weatherproof design
- Reliable drainage of rainwater
- Compact design
- Easy installation on flange
- Wide range of accessories available

Application

- Ideal for the extraction of corrosive gases
- Extraction of potentially explosive atmosphere

Design

- Internal motors separated from the air flow
- No metal parts in the air flow
- Shaft gap fitted as standard with seal
- Fitted as standard with repair switch or explosion-proof terminal box
- Available in many materials (PPs, PPs-el, PVC, ...)
- Use of explosion-proof motors possible



Suction side of the fan with threaded bushings for flange mounting

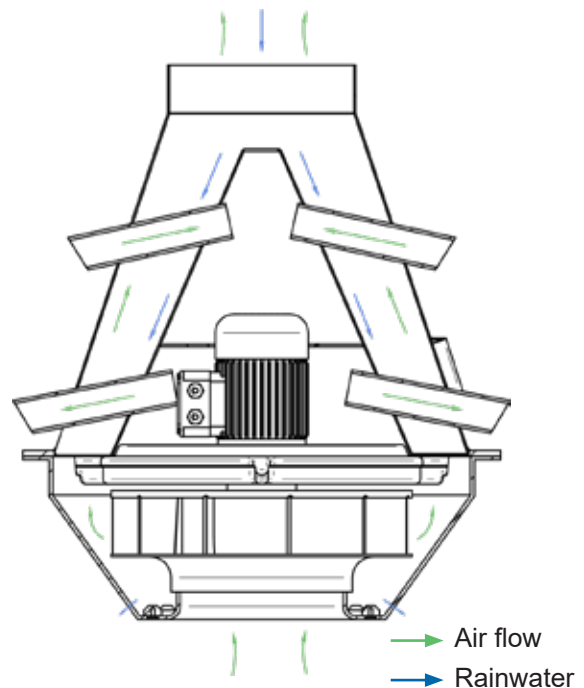

Accessories:

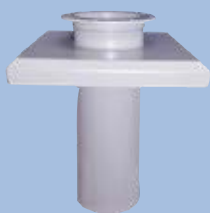

Roof mounting
DA1 without base
P. 44

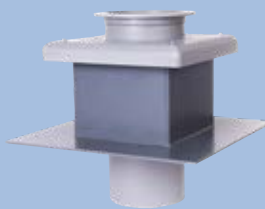

Roof mounting
DA2 with base
P. 46

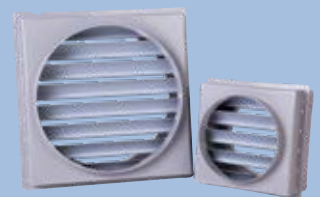

Silencer for roof fans
P. 64

Specification

HF - Roof fans

Corrosion resistant plastic radial roof fan with housing in thermoplastics, in stable, welded version, one inlet side, splinter protection according to accident prevention rules as plastic coated wire mesh. In case of upright mounting the exhaust air is blown out vertical according to requirements for aggressive air. All parts exposed to exhaust air are made of plastic or encapsulated by plastic. Shaft passage brought to minimum clearance using felt ring seal. Impeller with backward curved blades, floating-mounted on the motor shaft, statically and dynamically balanced, quality of balancing at least G 6.3 (DIN ISO 21940-11). Including internally mounted motor, encapsulated against the delivery medium, and outside mounted repair switch in case of standard motors (without ex-protection) respectively externally mounted terminal box for ex-motors. External ventilation for the motor via outward located ducts.

Manufacturer	: Hürner Luft- und Umwelttechnik	
Type	: HF D ... - 13 D	
Housing-material	: PPs	
Impeller-material	: PPs	
Inlet diameter	: ...	mm
Medium	: exhaust air	
Volume flow	: ...	m ³ /h
Total pressure difference	: ...	Pa
Static pressure difference	: ...	Pa
Sound pressure level Lp8A (1 m)	: ...	dB(A)
SFP	: ...	W/(m ³ /s)
Motor power	: ...	kW
Voltage	: 400	V
Frequency	: 50	Hz
Rated current	: ...	A
Enclosure / motor protection	: IP 55 / PTC	



Protection grid
P. 70



Fans optionally available
for Ex-Zone!
P. 72

HF - Roof fan
Type series HF D ...-13 D

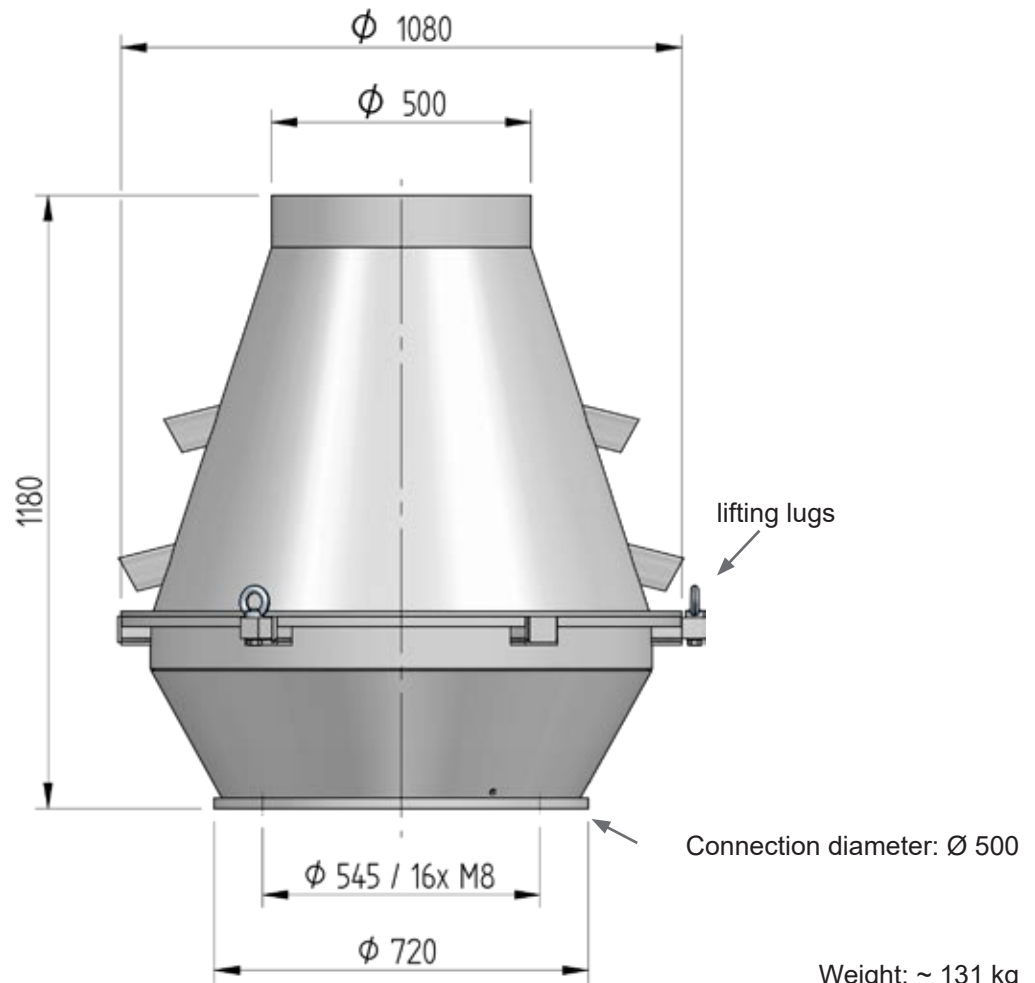
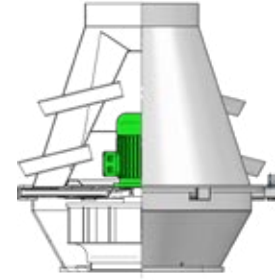

All dimensions in mm.

Accessories:



Roof mounting
DA1 without base
P. 44

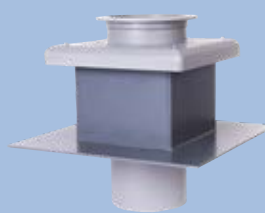

Roof mounting
DA2 with base
P. 46

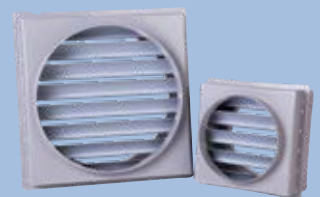

Silencer for roof fans
P. 64

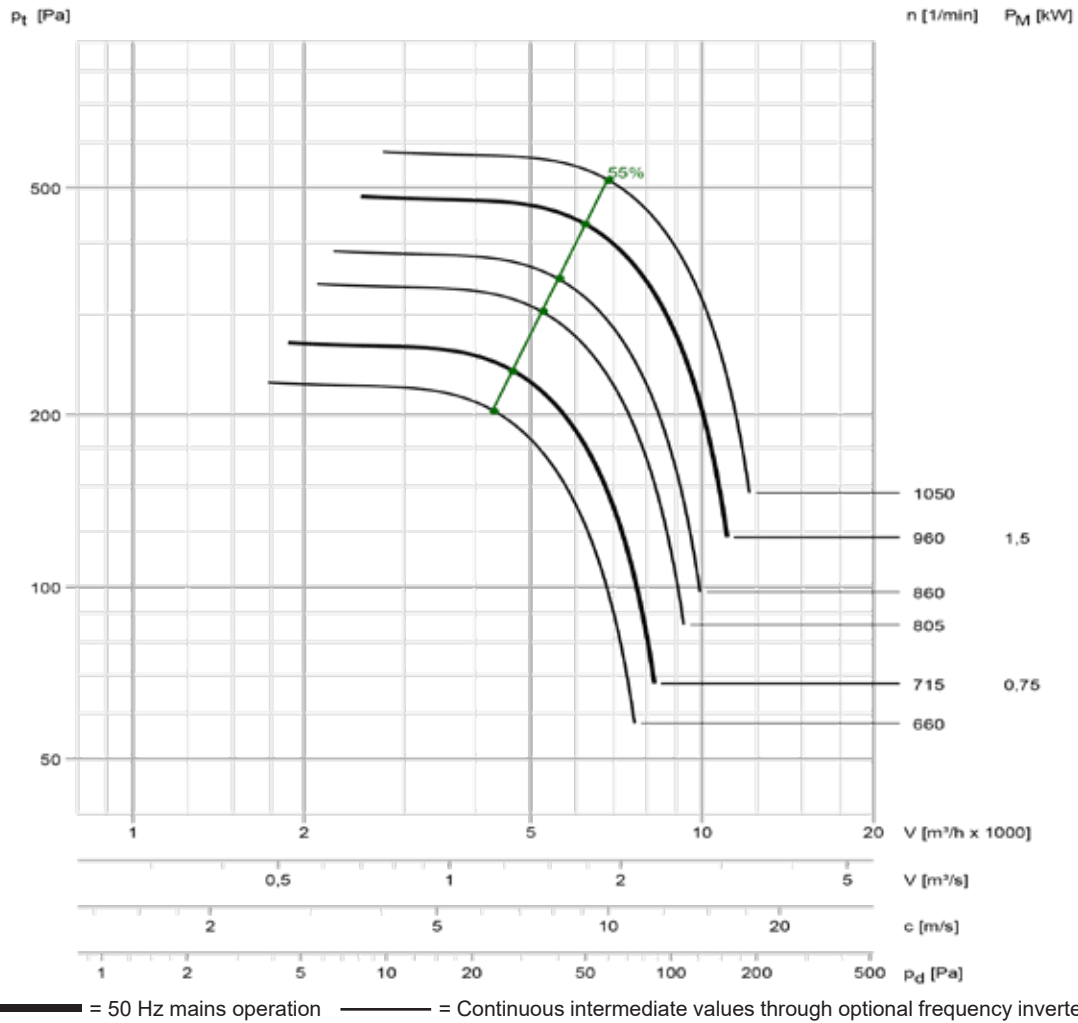

Acoustic level according to VDI 3731									
Speed [1/min]	inlet level / outlet level of the duct sound level non-valuated; $L_{w3} = L_{w4}$ [dB]								L_{p8A} (1 m) [dB(A)]
	63	125	250	500	1000	2000	4000	8000	
1050	87	85	92	78	74	68	62	55	76
960	85	83	90	77	72	66	60	53	74
860	83	81	88	74	70	64	57	50	72
805	82	80	87	73	68	62	56	48	71
715	78	86	73	68	63	58	51	43	63
660	77	84	71	67	62	56	49	41	62



Protection grid
P. 70



Fans optionally available
for Ex-Zone!
P. 72

HF - Roof fan
Type series HF D ...-13 D

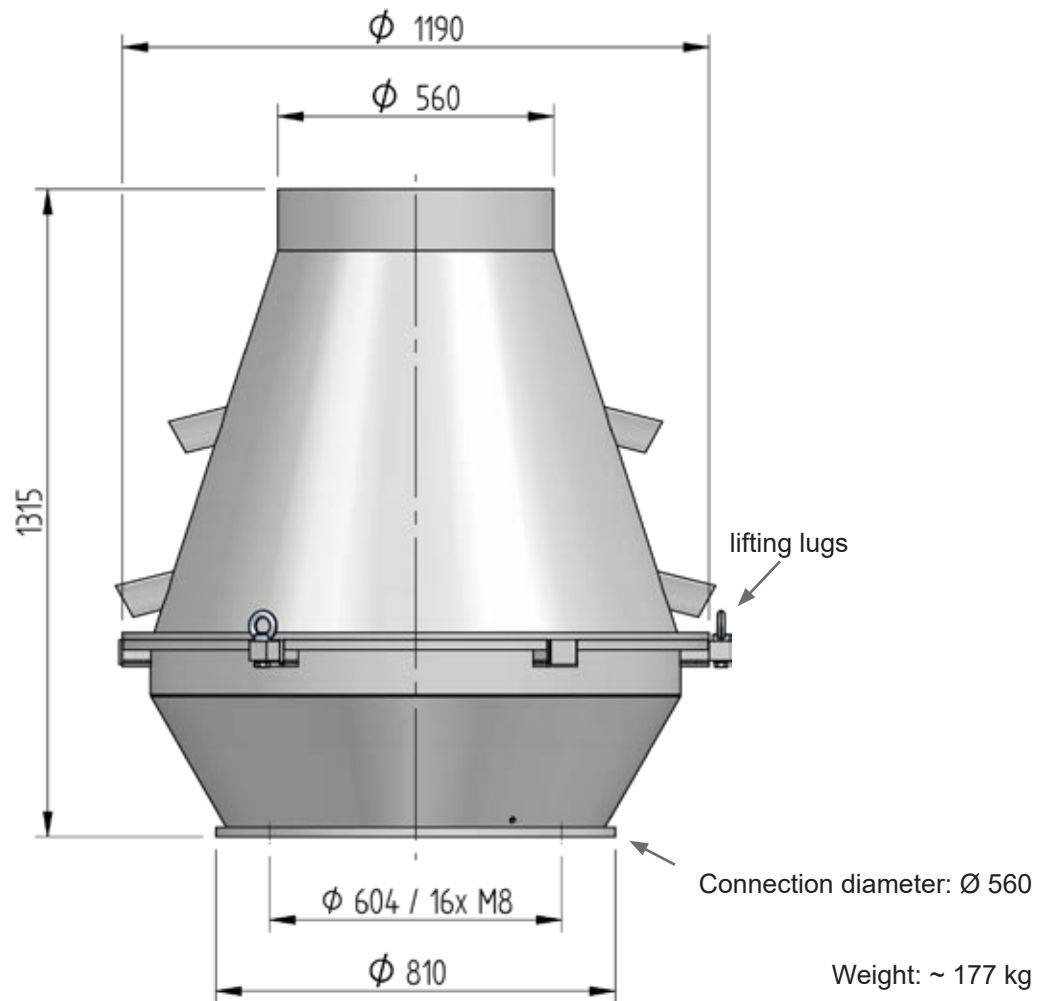
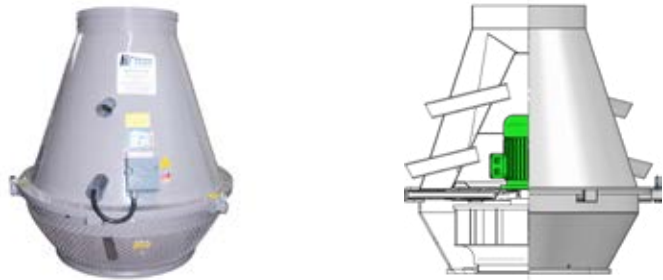

Weight: ~ 177 kg

All dimensions in mm.

Accessories:

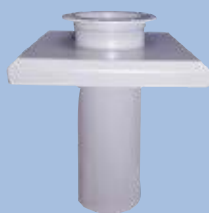

Roof mounting
DA1 without base
P. 44

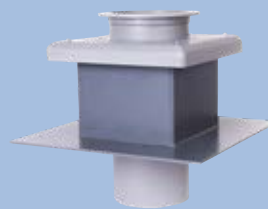

Roof mounting
DA2 with base
P. 46

HF D 560-13 D

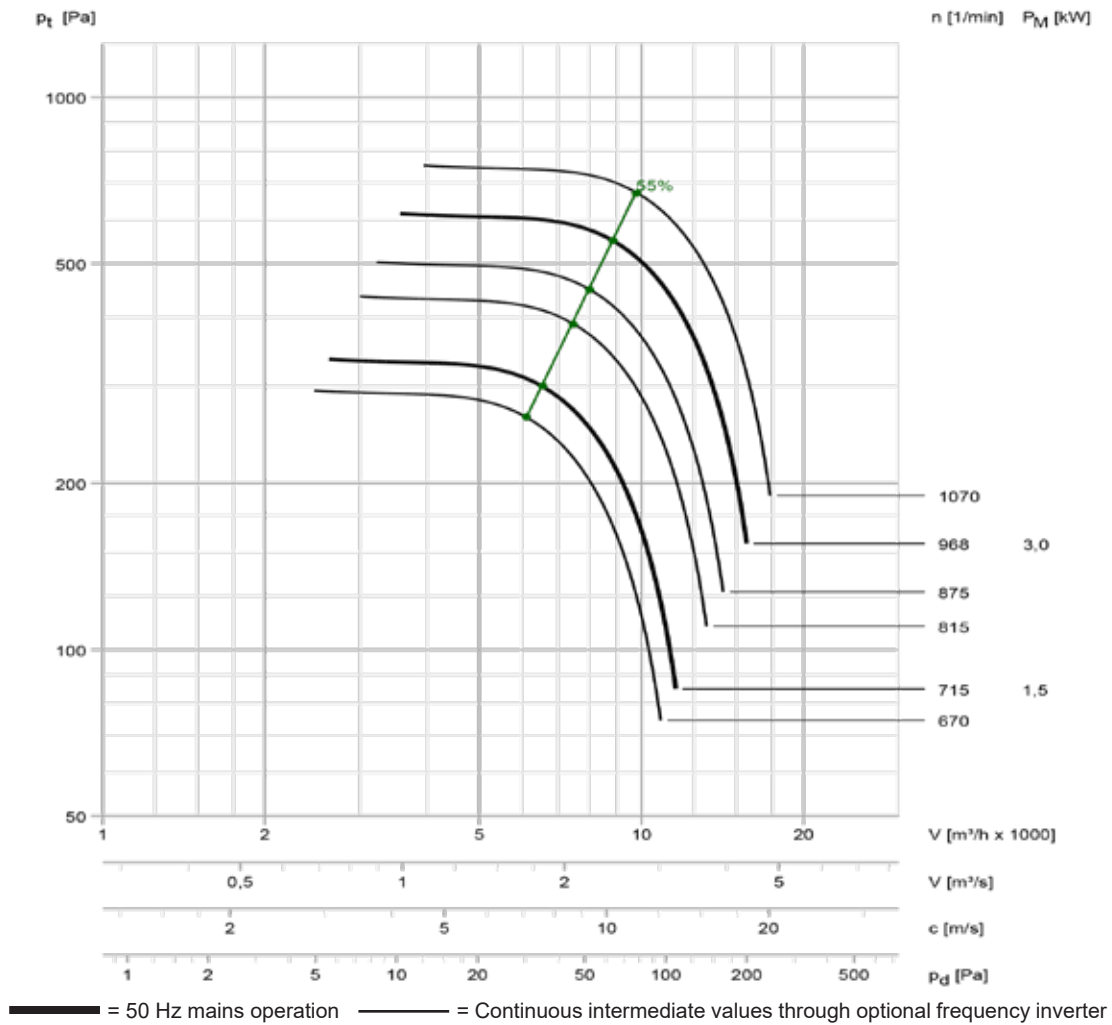

Acoustic level according to VDI 3731									
Speed [1/min]	inlet level / outlet level of the duct sound level non-valuated; Lw3 = Lw4 [dB]								Lp8A (1 m) [dB(A)]
	63	125	250	500	1000	2000	4000	8000	
1070	89	87	94	81	76	71	65	57	79
968	87	85	93	79	74	69	62	55	77
875	86	84	91	77	72	66	60	52	75
815	84	82	89	75	70	65	58	50	73
715	80	88	75	71	66	60	53	45	66
670	79	87	73	69	64	58	51	43	64

 Protection grid
 P. 70

 Fans optionally available
 for Ex-Zone!
 P. 72

HF - Roof fan
Type series HF D ...-13 D

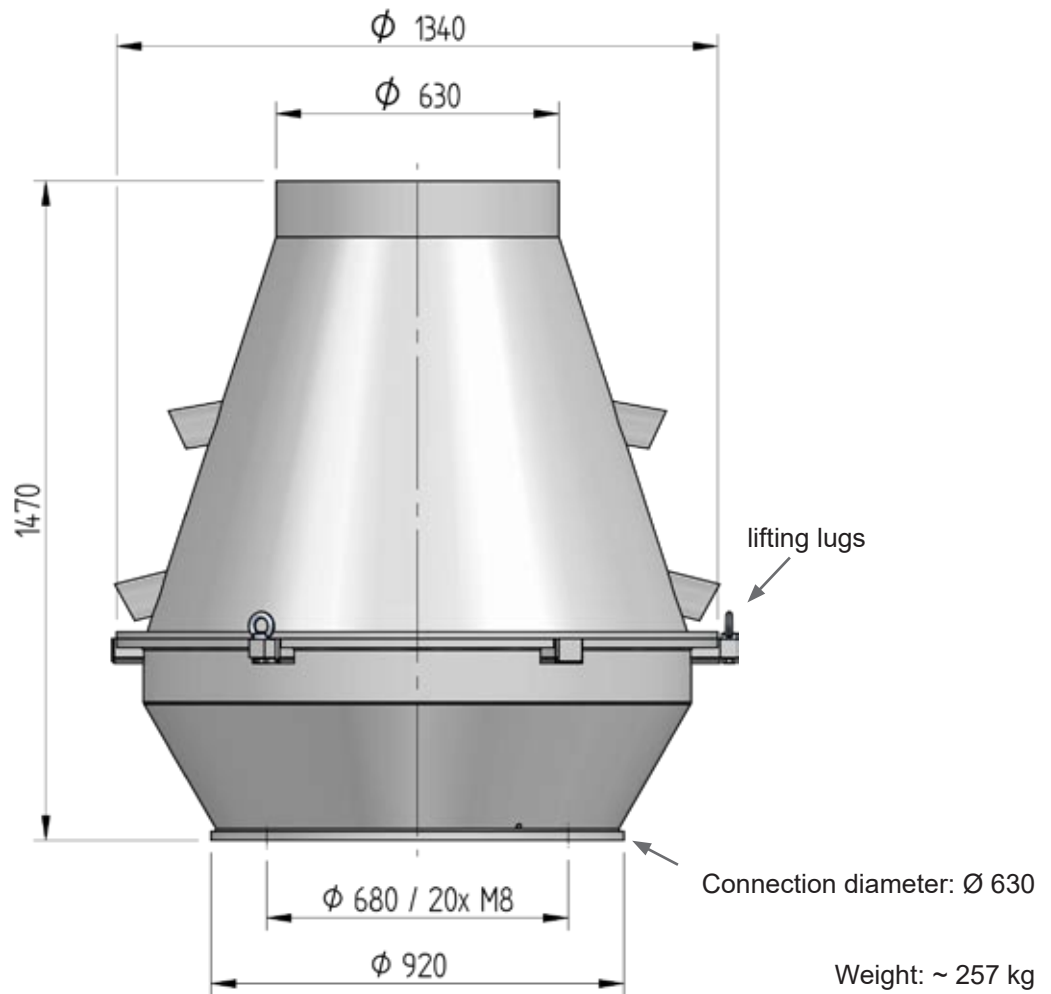
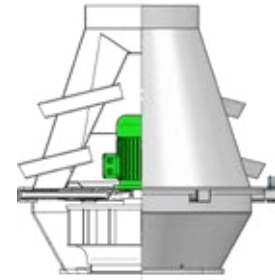

Weight: ~ 257 kg

All dimensions in mm.

Accessories:



Roof mounting
DA1 without base
P. 44

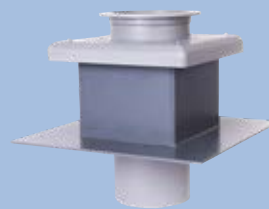

Roof mounting
DA2 with base
P. 46

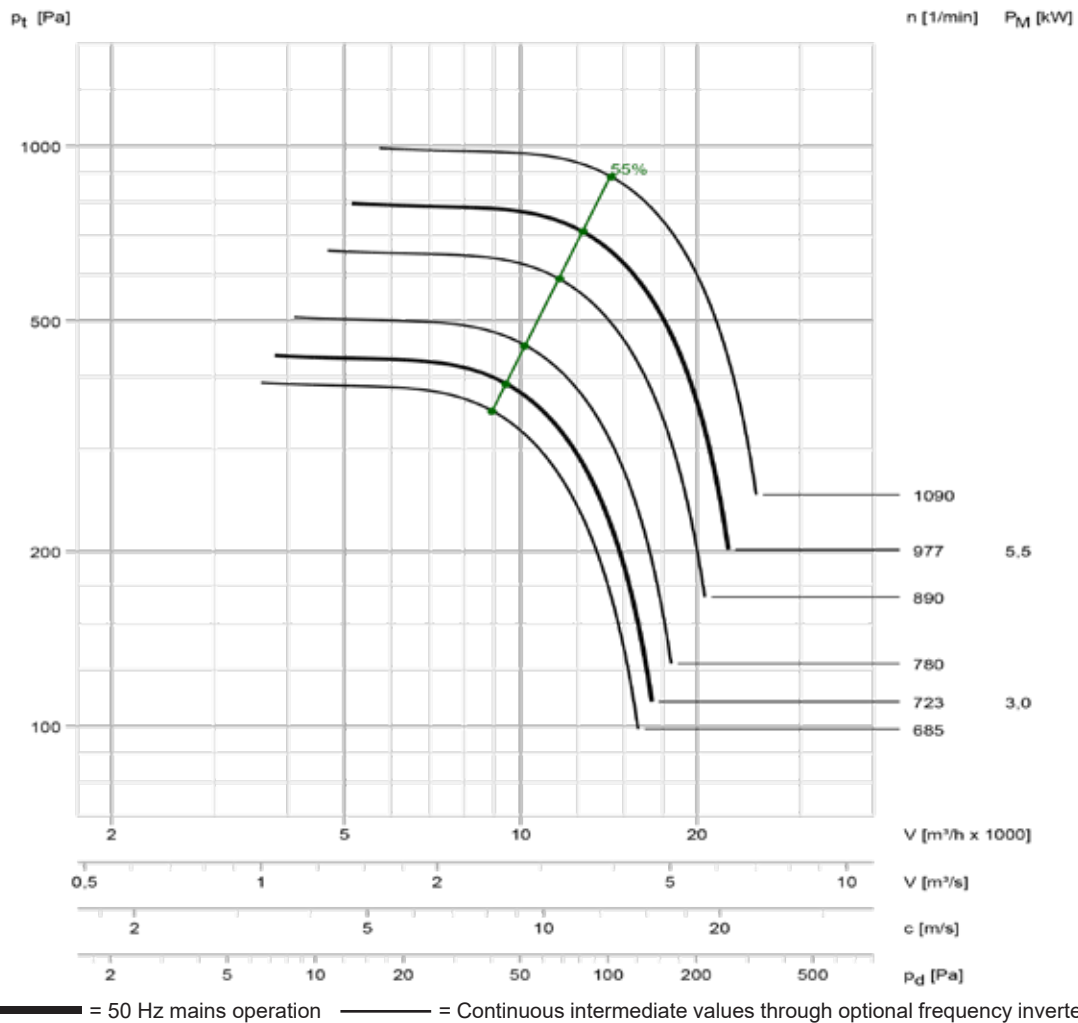

Acoustic level according to VDI 3731									
Speed [1/min]	inlet level / outlet level of the duct sound level non-valuated; Lw3 = Lw4 [dB]								Lp8A (1 m) [dB(A)]
	63	125	250	500	1000	2000	4000	8000	
1090	91	90	97	83	79	73	67	60	81
977	89	88	95	81	76	71	65	57	79
890	88	86	93	79	74	69	62	55	77
780	86	84	91	77	72	66	59	51	75
723	82	90	77	73	68	62	55	47	68
685	81	89	76	72	67	61	64	46	67



Protection grid
P. 70



Fans optionally available
for Ex-Zone!
P. 72

HF - Roof fan
Type series HF D ...-13 D

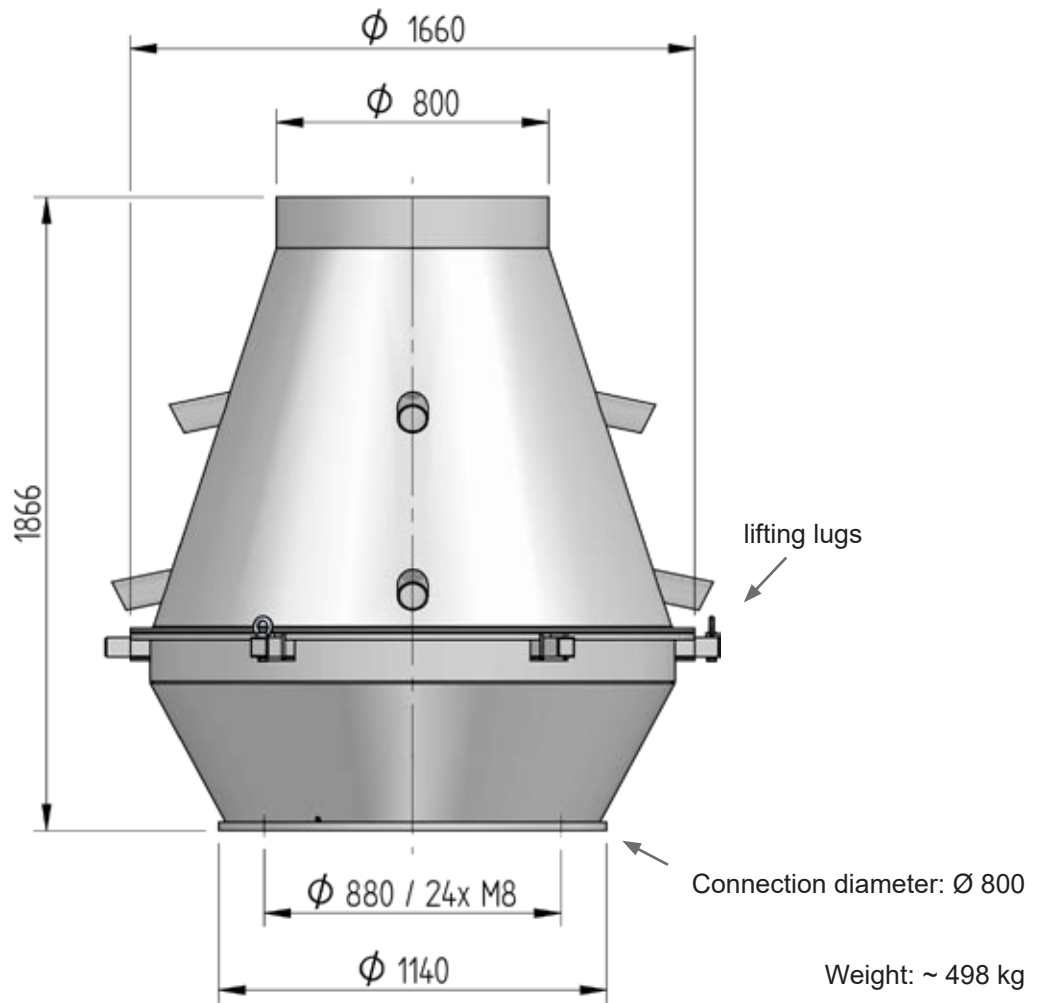
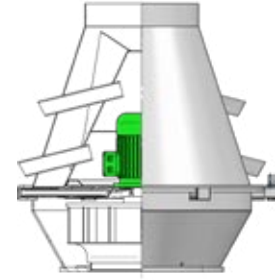

Accessories:

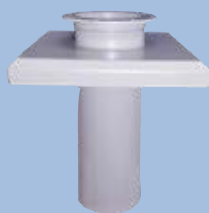

Roof mounting
DA1 without base
P. 44

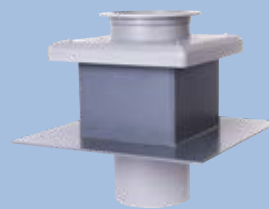

Roof mounting
DA2 with base
P. 46

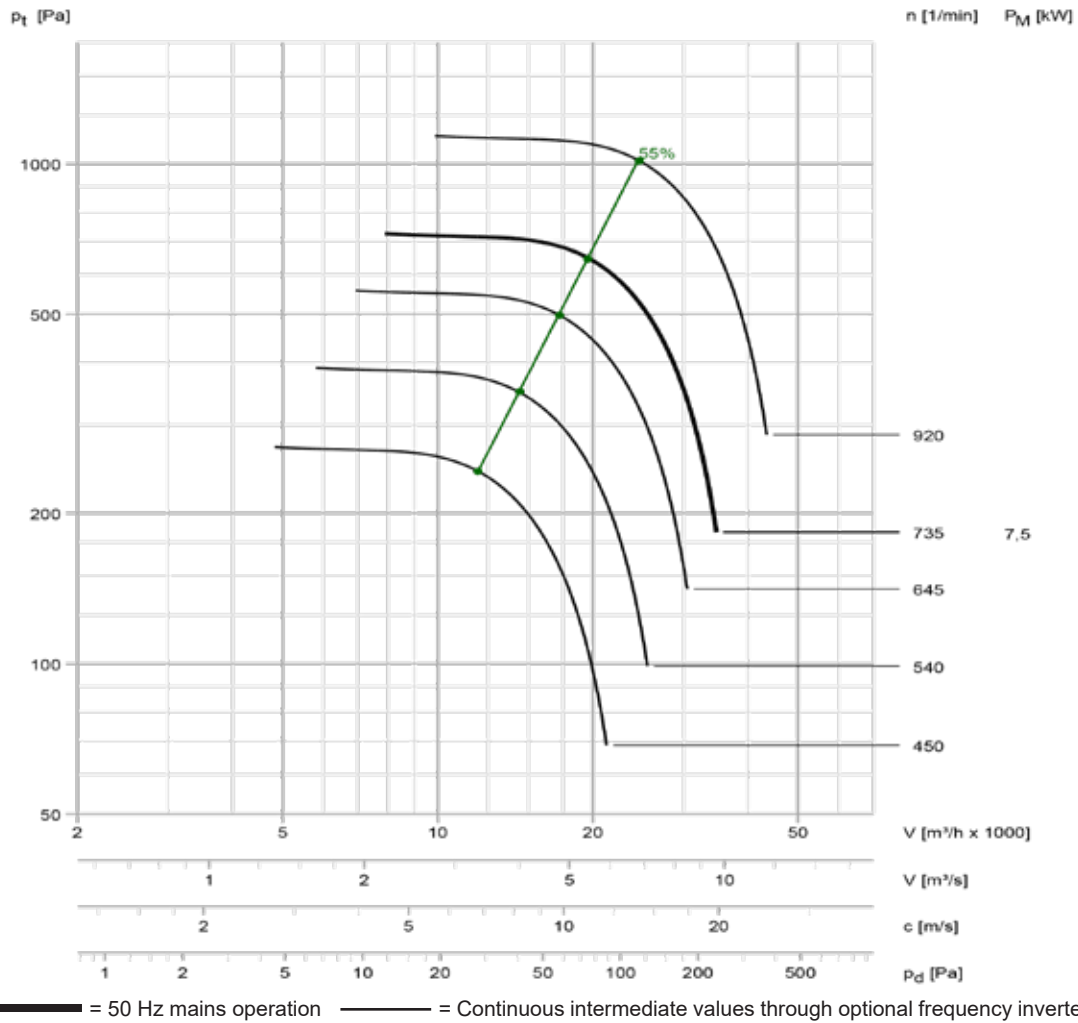

Acoustic level according to VDI 3731									
Speed [1/min]	inlet level / outlet level of the duct sound level non-valuated; Lw3 = Lw4 [dB]								Lp8A (1 m) [dB(A)]
	63	125	250	500	1000	2000	4000	8000	
920	93	91	98	84	79	74	67	60	82
735	87	95	82	78	73	67	60	52	73
645	85	92	79	75	70	64	57	49	70
540	82	89	75	71	66	59	52	44	67
450	78	85	72	67	61	55	47	39	63



Protection grid
P. 70



Fans optionally available
for Ex-Zone!
P. 72

HF - Roof fan
Type series HF D ...-13 D

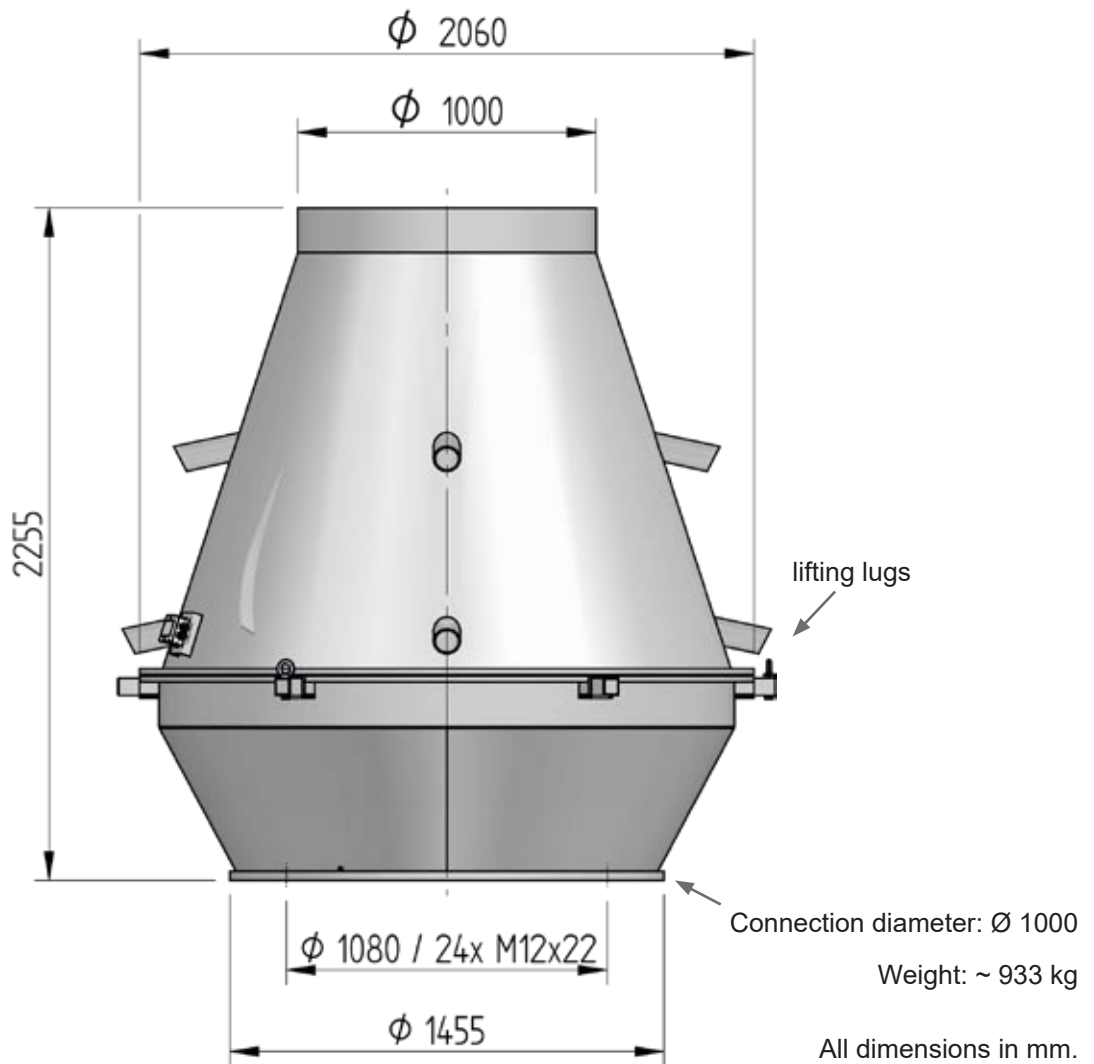
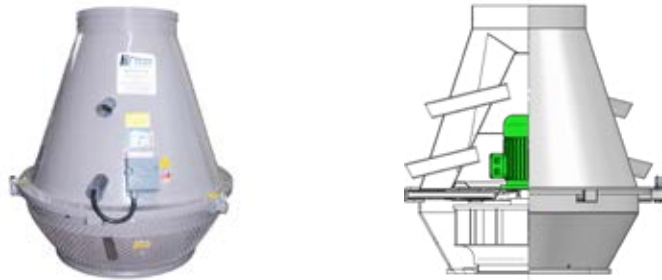

Accessories:



Roof mounting
DA1 without base
P. 44

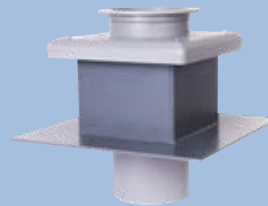

Roof mounting
DA2 with base
P. 46

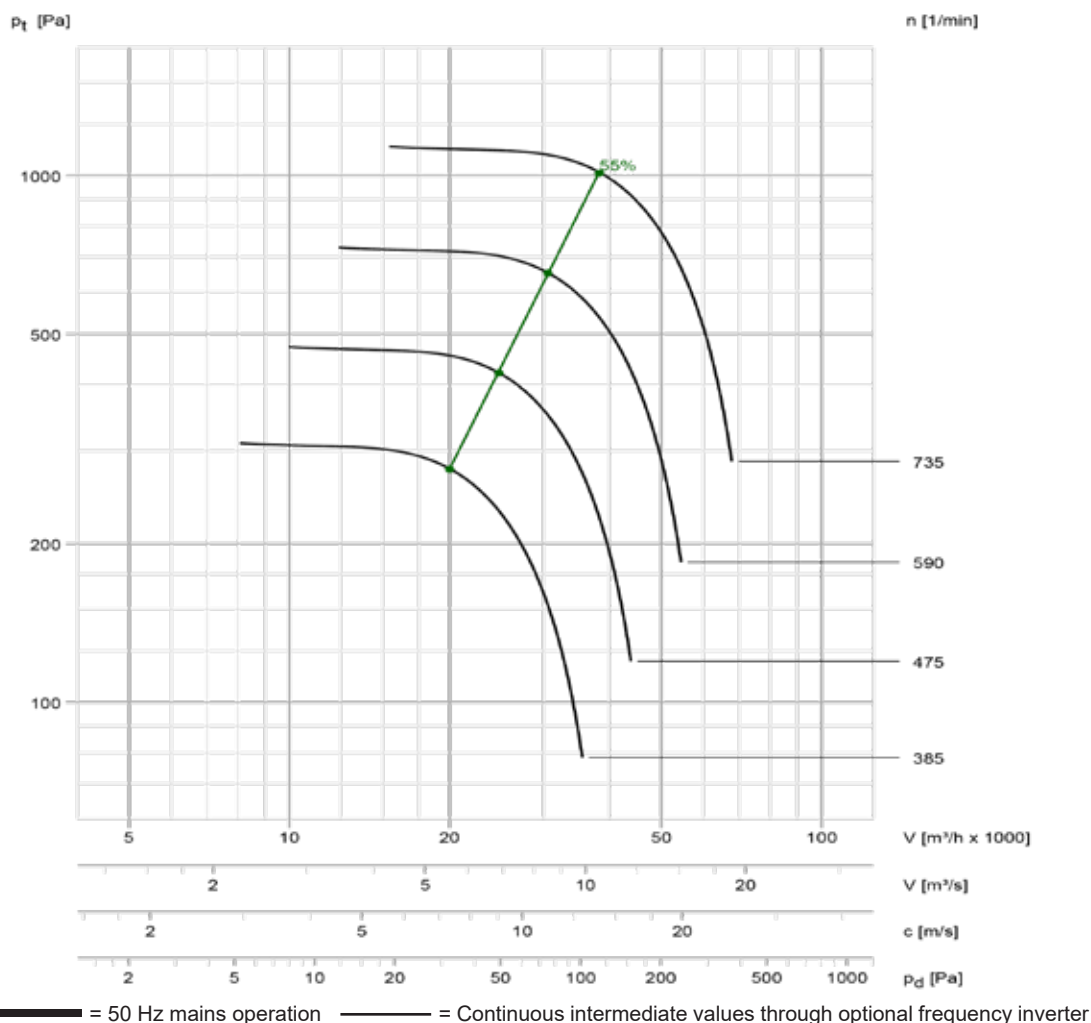

Acoustic level according to VDI 3731									
Speed [1/min]	inlet level / outlet level of the duct sound level non-valuated; Lw3 = Lw4 [dB]								Lp8A (1 m) [dB(A)]
	63	125	250	500	1000	2000	4000	8000	
735	91	99	86	82	77	71	64	56	77
590	87	95	81	77	72	65	58	50	73
475	83	91	77	72	57	60	53	45	68
385	87	74	70	65	59	53	45	36	59



Protection grid
P. 70



Fans optionally available
for Ex-Zone!
P. 72

Accessories
Roof mounting for on-site
roof attachment base for
HF - roof fans



Features

- For installation of roof fans on base provided by customer
- For existing bases
- Flange for direct installation of a fan
- Moulded rain collar

Key data

- Available for all roof fans in the nominal connection sizes 110 to 1000 mm
- Made of PPs material as standard
- Special materials optionally available
- 2 loose cable glands included in scope of delivery

HF - roof fans are installed directly on the roof attachments

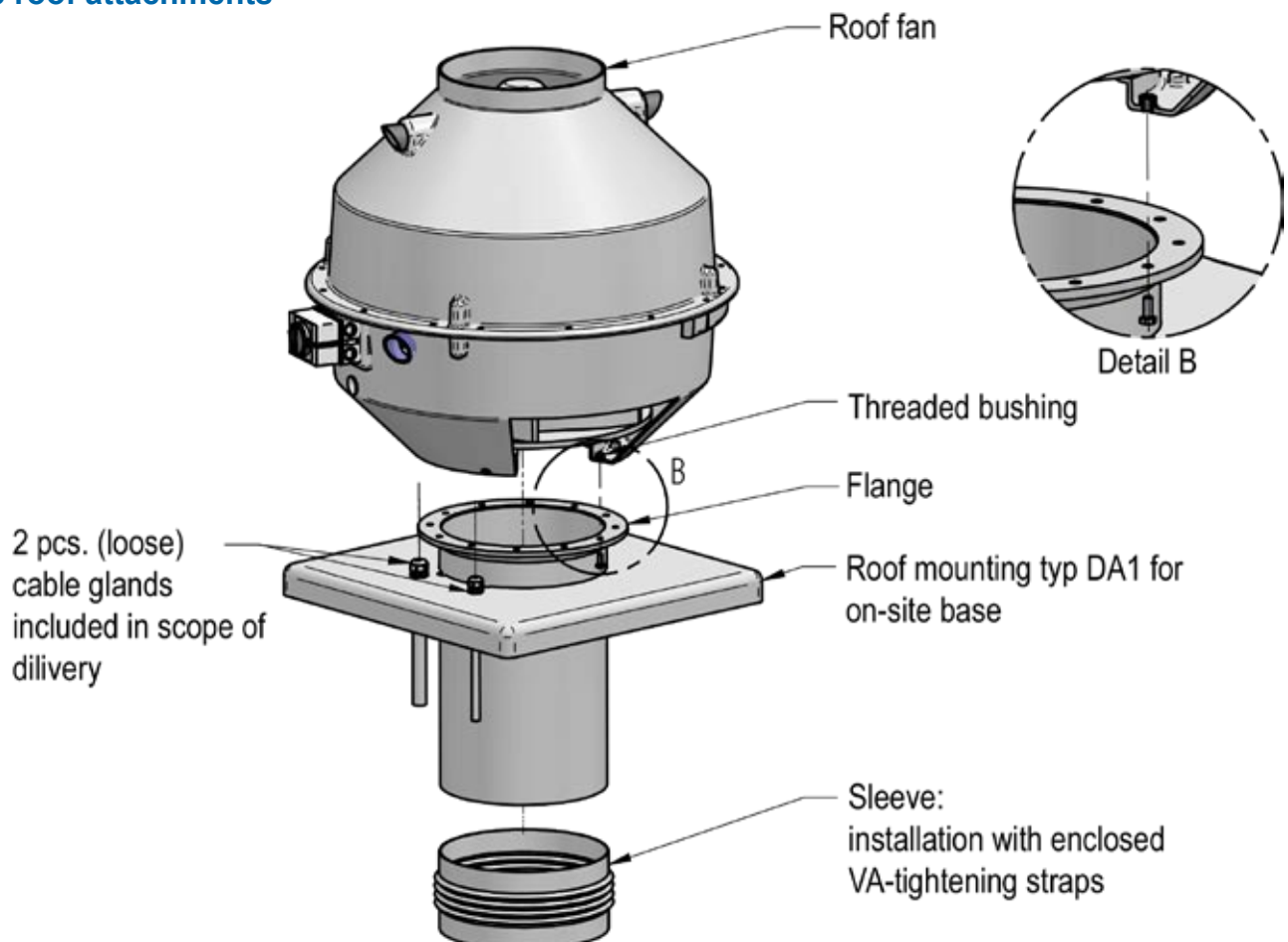

HF - DA1 without base



Accessories
Roof mounting for on-site
roof attachment base for
HF - roof fans

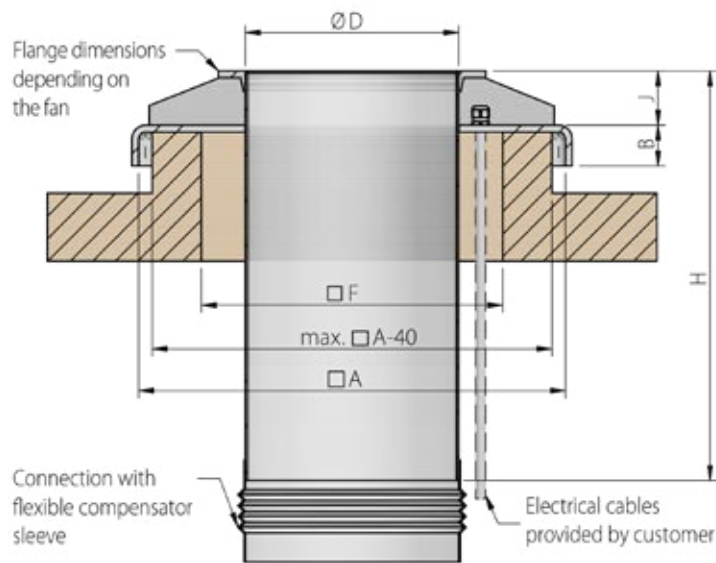

Size - Type	Dimensions [mm]									PPs	Connection with flexible compensator sleeve
	Ø	□A	B	□C	□E	□F	G	H	J		
110-17	350	60	535	200	235	300	600	80	415-010-000100	420-088-100079	
160-17	400	60	583	250	285	300	600	80	415-010-000200	420-088-100082	
200-17	450	60	630	295	330	300	600	80	415-010-000300	420-088-100085	
250-15	450	60	630	295	330	300	600	80	415-010-000400	420-088-100086	
250-17	450	60	630	295	330	300	600	80	415-010-000400	420-088-100086	
315-15	630	60	745	410	445	300	600	80	415-010-000500	420-088-100087	
160-16	400	60	583	250	285	300	600	80	415-010-000600	420-088-100082	
200-16	450	60	630	295	330	300	600	80	415-010-000700	420-088-100085	
250-16	450	60	630	295	330	300	600	80	415-010-000800	420-088-100086	
315-16	630	60	745	410	445	300	600	80	415-010-000900	420-088-100087	
355-16	630	60	795	455	495	300	640	120	415-010-001000	420-081-000112	
400-16	630	60	795	455	495	300	640	120	415-010-001100	420-081-000113	
500-13	1000	60	955	610	655	300	670	150	415-010-001200	420-081-000115	
560-13	1000	60	1055	710	755	300	670	150	415-010-001300	420-081-000118	
630-13	1000	60	1055	710	755	300	670	150	415-010-001400	420-081-000122	
800-13	1300	60	1245	900	945	300	690	170	415-010-001500	420-081-000513	
1000-13	1500	60	1445	1100	1145	300	750	230	415-010-001600	420-081-000515	

Other versions optionally available.

Accessories
Roof mounting with
roof attachment base with
0° roof pitch for
HF - roof fans



Features

- For the installation of roof fans on flat and inclined roofs
- Ideal for sealing into the roof through the square PVC base
- Flange for direct installation of a fan
- Optionally available with integrated blind flap

Key data

- Available for all roof fans in the nominal connection sizes 110 to 1000 mm
- Available as standard version for 0° roof pitch, optionally available for fixed roof pitch of up to 45°
- Made of PPs material as standard, with PVC basel
- Special materials optionally available
- 2 loose cable glands included in scope of delivery

**HF - roof fans are installed directly on
the roof attachments**

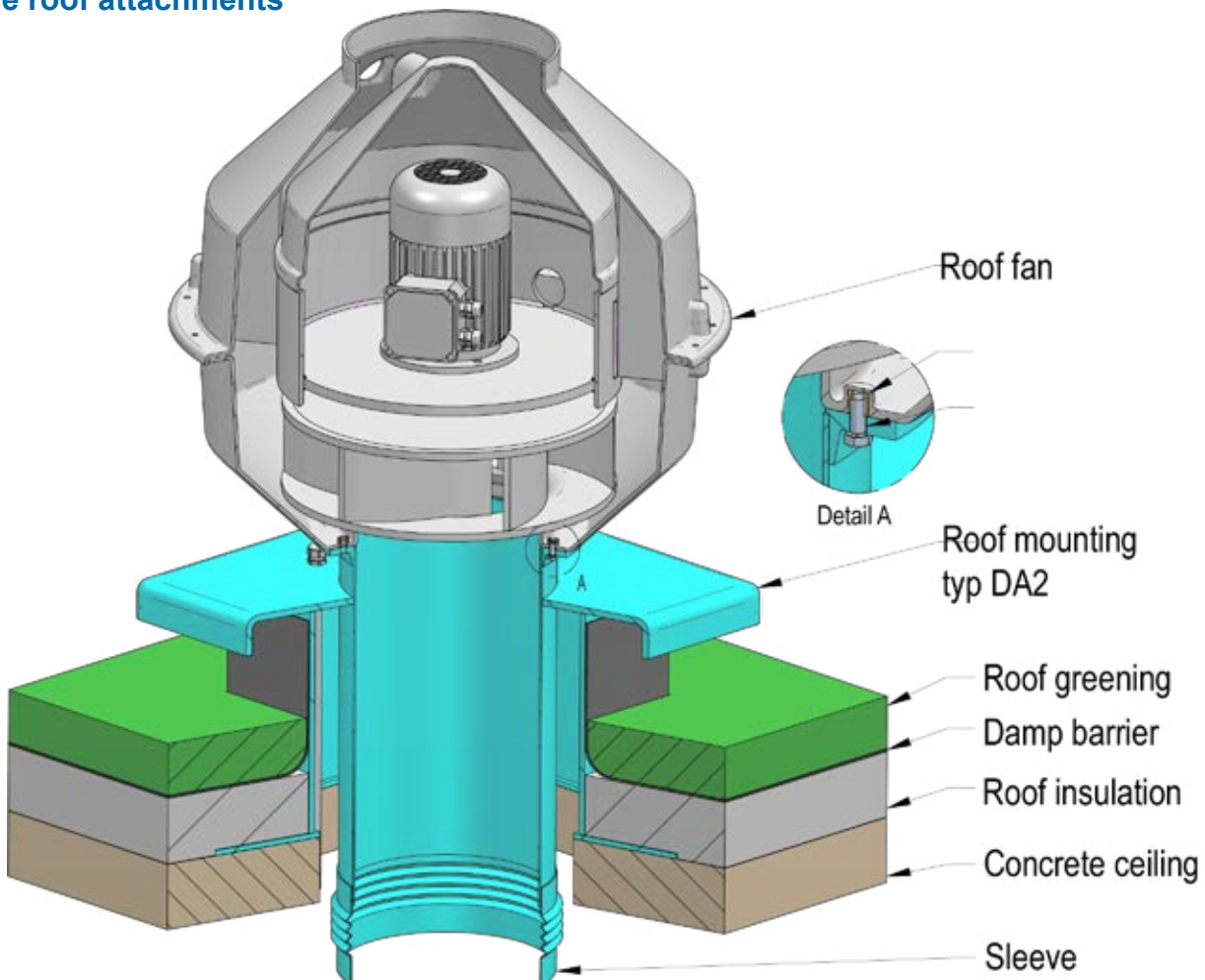



Accessories
Roof mounting with
roof attachment base with
0° roof pitch for
HF - roof fans

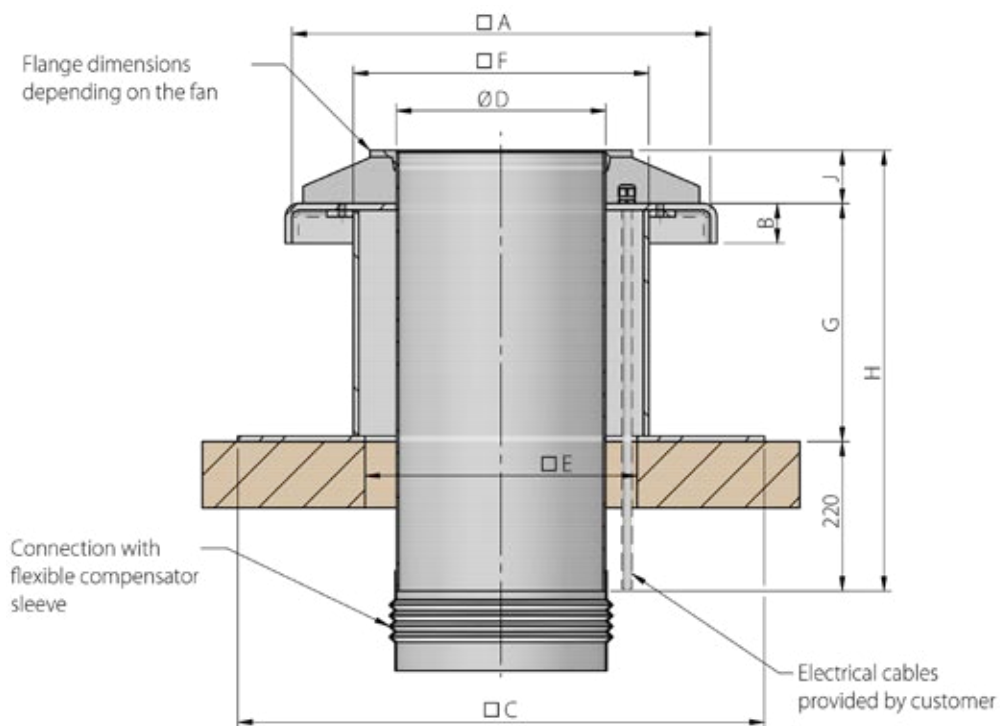

Size - Type	Dimensions [mm]								PPs / PVC	Connection with flexible compensator sleeve
	Ø	□A	B	□C	□E	□F	G	H	J	Article no.
110-17	350	60	535	200	235	300	600	80	415-011-000300	420-088-100079
160-17	400	60	583	250	285	300	600	80	415-011-000600	420-088-100082
200-17	450	60	630	295	330	300	600	80	415-011-000900	420-088-100085
250-15	450	60	630	295	330	300	600	80	415-011-001200	420-088-100086
250-17	450	60	630	295	330	300	600	80	415-011-001200	420-088-100086
315-15	630	60	745	410	445	300	600	80	415-011-001500	420-088-100087
160-16	400	60	583	250	285	300	600	80	415-011-001800	420-088-100082
200-16	450	60	630	295	330	300	600	80	415-011-002100	420-088-100085
250-16	450	60	630	295	330	300	600	80	415-011-002400	420-088-100086
315-16	630	60	745	410	445	300	600	80	415-011-002700	420-088-100087
355-16	630	60	795	455	495	300	640	120	415-011-003000	420-081-000112
400-16	630	60	795	455	495	300	640	120	415-011-003300	420-081-000113
500-13	1000	60	955	610	655	300	670	150	415-011-003600	420-081-000115
560-13	1000	60	1055	710	755	300	670	150	415-011-003900	420-081-000118
630-13	1000	60	1055	710	755	300	670	150	415-011-004200	420-081-000122
800-13	1300	60	1245	900	945	300	690	170	415-011-004500	420-081-000513
1000-13	1500	60	1445	1100	1145	300	750	230	415-011-004800	420-081-000515

Other versions optionally available.

Accessories
 Roof mounting with
 roof attachment base with
 roof pitch up to 45° for
 HF - roof fans

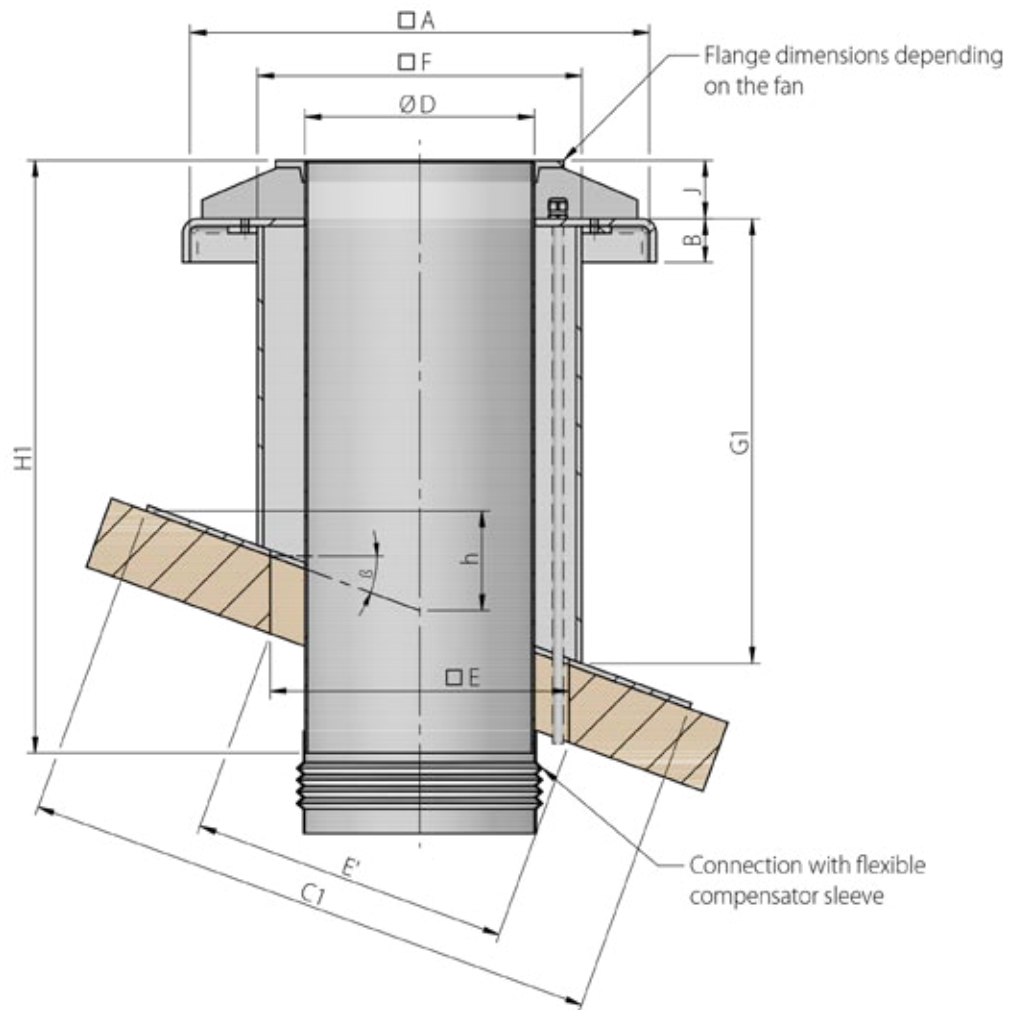
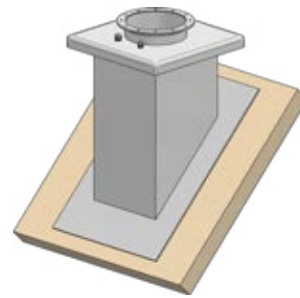

Please let us know your roof pitch.
 You will receive an individual dimension drawing.



Accessories
Roof mounting with
roof attachment base and
blind flap with 0° roof pitch for
HF - roof fans

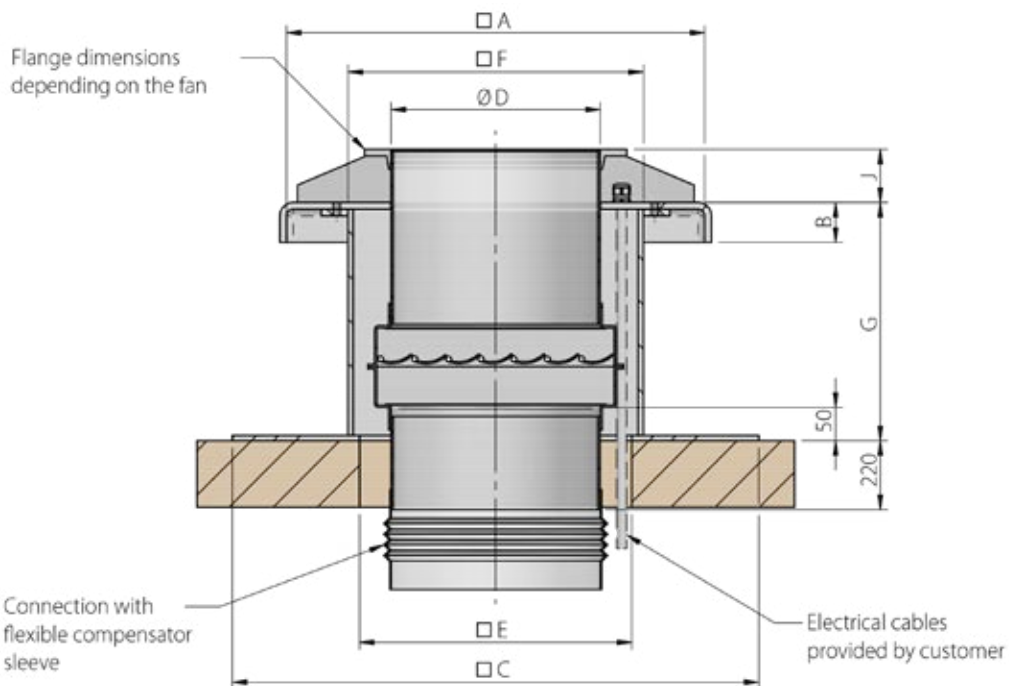

Size - Type	Dimensions [mm]								PPs / PVC	Connection with flexible compensator sleeve
	Ø	□A	B	□C	□E	□F	G	H	J	Article no.
110-17	350	60	535	200	235	300	600	80	415-014-000200	420-088-100079
160-17	400	60	583	250	285	300	600	80	415-014-000400	420-088-100082
200-17	450	60	630	295	330	300	600	80	415-014-000600	420-088-100085
250-15	450	60	630	295	330	300	600	80	415-014-000800	420-088-100086
250-17	450	60	630	295	330	300	600	80	415-014-000800	420-088-100086
315-15	630	60	745	410	445	300	600	80	415-014-001000	420-088-100087
160-16	400	60	583	250	285	300	600	80	415-014-001200	420-088-100082
200-16	450	60	630	295	330	300	600	80	415-014-001400	420-088-100085
250-16	450	60	630	295	330	300	600	80	415-014-001600	420-088-100086
315-16	630	60	745	410	445	300	600	80	415-014-001800	420-088-100087
355-16	630	60	795	455	495	300	640	120		420-081-000112
400-16	630	60	795	455	495	300	640	120		420-081-000113
500-13	1000	60	955	610	655	300	670	150		420-081-000115

Other versions optionally available.

Accessories

Base extension for roof mounting with roof attachment base with 0° roof pitch for HF - roof fans

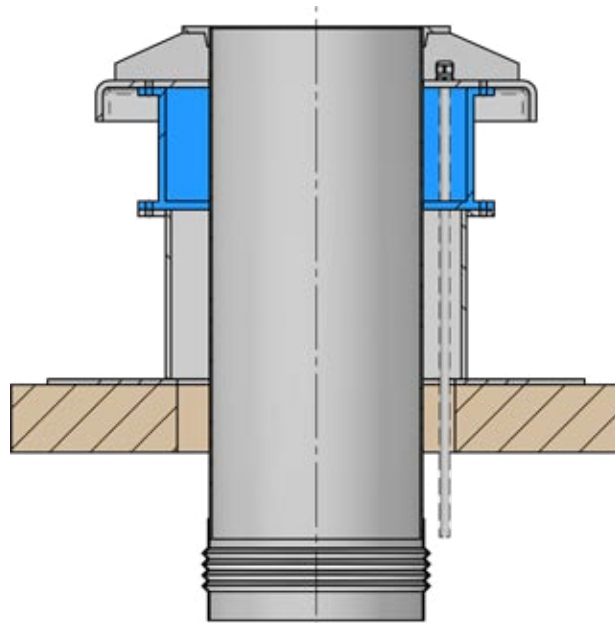
**Base extension**
Installation situation in conjunction with DA2 roof mounting base**Description of use**

A base extension is intended for applications in which higher roof structures (insulation, sealing, gravel layers, ...) have to be bridged with existing type DA2 roof mounting.

Wall bracket



Accessories
for wall mounting of
HF D ...-15 / 17 D

Wall bracket

For easy wall mounting

Size - Type	Dimension [mm]	Wall bracket
Ø	A	Article no.
110-17	460	017-829-102000
160-17	650	017-829-104000
200-17	650	017-829-104000
250-15	650	017-829-104000
250-17	650	017-829-108000
315-15	770	017-829-108000

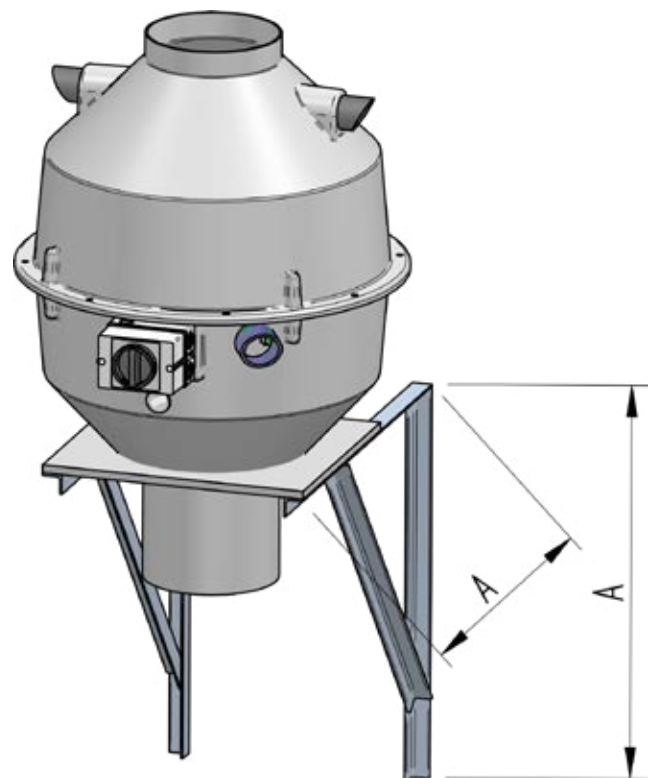

Wall consoles for HF roof fans of the
HF D ...-16 D series are optionally available.

Mounting plate for wall console

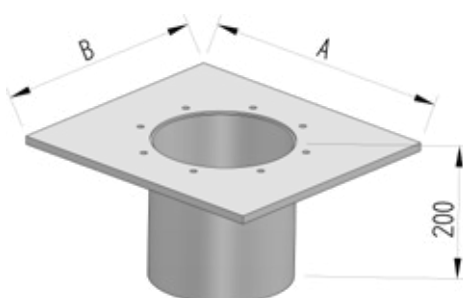

Size - Type	Dimension [mm]		PPs	PVC
Ø	A	B	Article no.	Article no.
110-17	310	350	436-012-000005	436-002-000005
160-17	360	360	436-012-000010	436-002-000010
200-17	400	360	436-012-000015	436-002-000015
250-15	450	360	436-012-000020	436-002-000020
250-17	450	360	436-012-000020	436-002-000020
315-15	515	420	436-012-000030	436-002-000030

Accessories

Silencer without cable bushing for HF D ...-15 / 17 D and HF D ...-16 D



Advantages

- Made of corrosion-resistant plastic
- Available for flat roof or inclined roof

Application

- For sound attenuation in direct connection with HF roof fans: standard for HF D ...-15 / 17 D and HF D ...-16 D

Product designation:

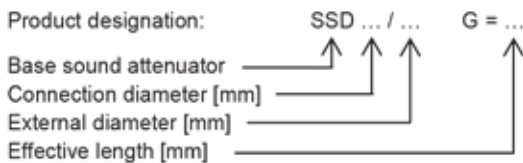

Design

- Sturdy welded housing with flange for fan, rain collar and roof attachment plate
- Nominal connection sizes from 110 to 400 mm, larger nominal sizes possible on request
- Roof attachment piece for flat roof, optionally available for inclined roof
- Absorption material made of non-combustible mineral wool according to DIN 4102, shrink-wrapped so it is abrasion-resistant and moisture-proof
- Made as standard from PPs material or PVC, other materials optionally available

Specification

HF silencer for roof fans made of plastic,
 Material: PPs

In round design, with welded-on rain collar. Sturdy housing with pipe connection and integrated housing including integrated roof attachment piece for mounting an HF roof fan: Type: **HF D ... - .. D**

Absorption material made of non-combustible mineral wool according to DIN 4102, shrink-wrapped or covered with acoustically transparent plastic foil. Covering of the absorption material by means of perforated plastic plate, material as housing.

Brand	: Hürner Luft- und Umwelttechnik	
Type	: HF SSD	
Connection diameter	: ...	mm
External diameter	: ...	mm
Effective length	: ...	mm
Total height	: ...	mm
Connection type	: 300 mm long pipe connection	
Attenuation	: ...	dB / 250 Hz

The standard base sound attenuator is supplied without cable bushing to the building.
 The variants with cable bushing are optionally available at extra cost.

HF - SSD without cable bushing



Accessories
Silencer without cable
bushing for
HF D ...-15 / 17 D and
HF D ...-16 D

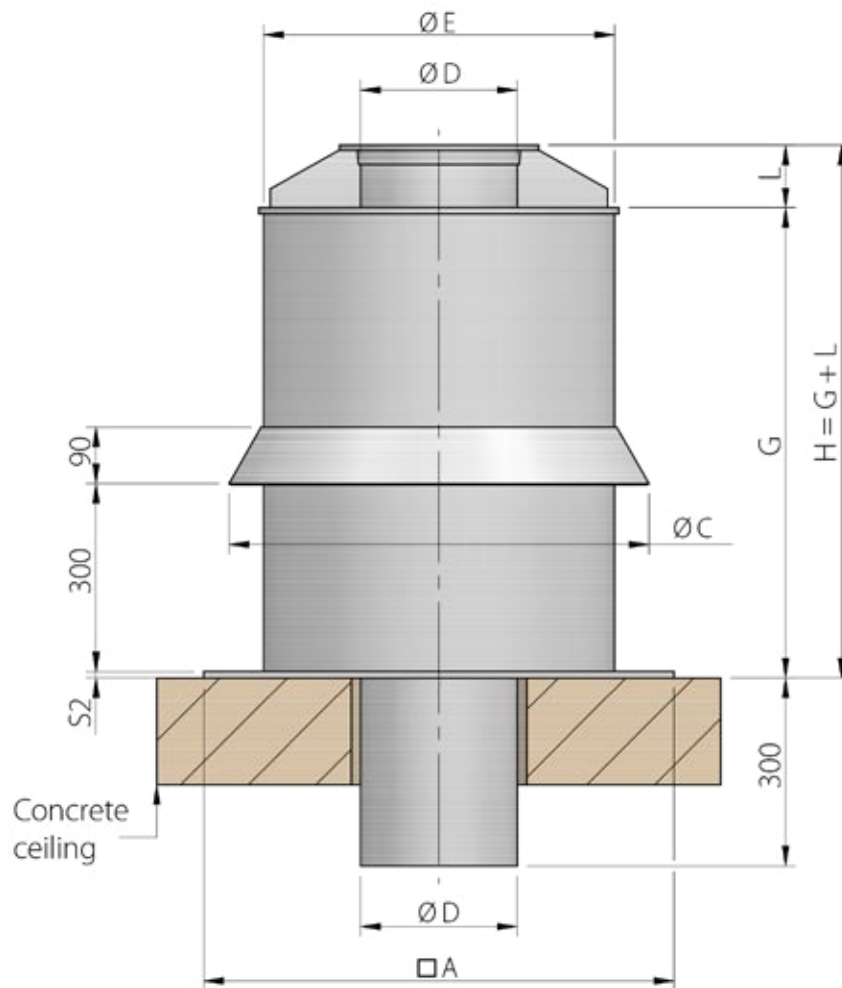

PPs									
Size - Type	Dimension [mm]					Effective length [mm]			
	□A	ØC	ØE	S2	L	G = 500	G = 750	G = 1000	G = 1200
110-17	750	510	400	10	100	408-012-000010	408-012-000090	408-012-000170	
160-17	750	560	450	10	100	408-012-000020	408-012-000100	408-012-000180	408-012-000260
200-17	750	610	500	10	100	408-012-000030	408-012-000110	408-012-000190	408-012-000270
250-15	750	670	560	10	100	408-012-000040	408-012-000120	408-012-000200	408-012-000280
250-17	750	670	560	10	100	408-012-000040	408-012-000120	408-012-000200	408-012-000280
315-15	900	740	630	10	100	408-012-000050	408-012-000130	408-012-000210	408-012-000290
315-16	900	740	630	10	100	408-012-000060	408-012-000140	408-012-000220	408-012-000300
355-16	950	767	657	10	100	408-012-000070	408-012-000150	408-012-000230	408-012-000310
400-16	1000	910	800	10	100	408-012-000080	408-012-000160	408-012-000240	408-012-000320

Accessories
Silencer with cable
bushing for
HF D ...-15 / 17 D and
HF D ...-16 D



Advantages

- Made of corrosion-resistant plastic
- Available for flat roof or inclined roof

Application

- For sound attenuation in direct connection with HF roof fans:
standard for HF D ...-15 / 17 D
and HF D ...-16 D

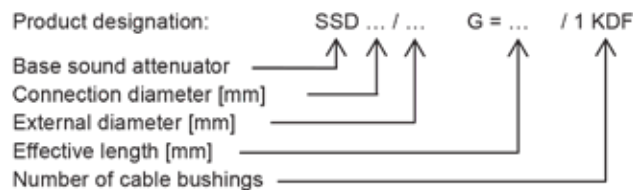

Design

- Sturdy welded housing with flange for fan, rain collar and roof attachment plate
- Nominal connection sizes from 110 to 400 mm, larger nominal sizes possible on request
- Roof attachment piece for flat roof, optionally available for inclined roof
- Absorption material made of non-combustible mineral wool according to DIN 4102, shrink-wrapped so it is abrasion-resistant and moisture-proof
- Made as standard from PPs material or PVC, other materials optionally available
- One integrated cable bushing for the through-wiring of the motor connecting cable

Specification

HF silencer for roof fans made of plastic,
Material: PPs

In round design, with welded-on rain collar. Sturdy housing with pipe connection and

integrated cable bushing: 1 piece: **M 25 x 1,5**

Cable bushing with cable gland according to DIN EN 50262 / IP 68. Sealing area with strain relief for cable diameter 9 - 17 mm.

housing including integrated roof attachment piece for mounting an HF roof fan: Type: **HF D ... - .. D**

Absorption material made of non-combustible mineral wool according to DIN 4102, shrink-wrapped or covered with acoustically transparent plastic foil. Covering of the absorption material by means of perforated plastic plate, material as housing.

Brand	: Hürner Luft- und Umwelttechnik	
Type	: HF SSD	
Connection diameter	: ...	mm
External diameter	: ...	mm
Effective length	: ...	mm
Total height	: ...	mm
Connection type	: 300 mm long pipe connection	
Attenuation	: ...	dB / 250 Hz

HF - SSD with two cable bushings



Accessories
Silencer with two cable
bushings for
HF D ...-15 / 17 D and
HF D ...-16 D

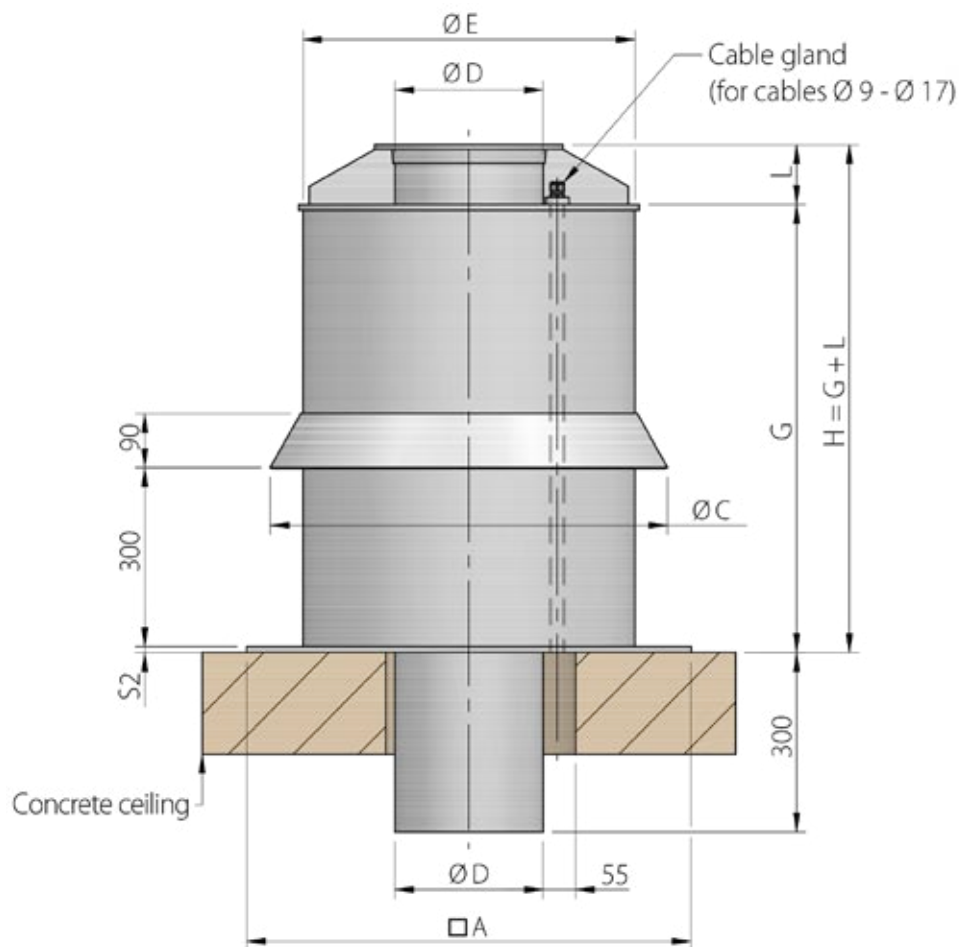

PPs									
Size - Type	Dimension [mm]					Effective length [mm]			
\varnothing	$\square A$	$\varnothing C$	$\varnothing E$	$S2$	L	$G = 500$	$G = 750$	$G = 1000$	$G = 1200$
110-17	750	510	400	10	100	408-012-000350	408-012-000430	408-012-000510	
160-17	750	560	450	10	100	408-012-000360	408-012-000440	408-012-000520	408-012-000600
200-17	750	610	500	10	100	408-012-000370	408-012-000450	408-012-000530	408-012-000610
250-15	750	670	560	10	100	408-012-000380	408-012-000460	408-012-000540	408-012-000620
250-17	750	670	560	10	100	408-012-000380	408-012-000460	408-012-000540	408-012-000620
315-15	900	740	630	10	100	408-012-000390	408-012-000470	408-012-000550	408-012-000630
315-16	900	740	630	10	100	408-012-000400	408-012-000480	408-012-000560	408-012-000640
355-16	950	767	657	10	100	408-012-000410	408-012-000490	408-012-000570	408-012-000650
400-16	1000	910	800	10	100	408-012-000420	408-012-000500	408-012-000580	408-012-000660

Accessories
Silencer with two cable bushings for
HF D ...-15 / 17 D and
HF D ...-16 D



Advantages

- Made of corrosion-resistant plastic
- Available for flat roof or inclined roof

Application

- For sound attenuation in direct connection with HF roof fans:
standard for HF D ...-15 / 17 D and HF D ...-16 D

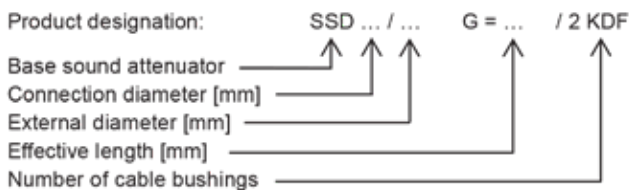

Specification

HF silencer for roof fans made of plastic,
Material: PPs

In round design, with welded-on rain collar. Sturdy housing with pipe connection and **two integrated cable bushings**:

1 piece: **M 25 x 1,5**

Cable bushing with cable gland according to DIN EN 50262/IP 68. Sealing area with strain relief for cable diameter 9 - 17 mm.

1 piece: **M 20 x 1,5**

Cable bushing with cable gland according to DIN EN 50262/IP 68. Sealing area with strain relief for cable diameter 6 - 13 mm.

housing including integrated roof attachment piece for mounting an HF roof fan: Type: **HF D ... - .. D**

Absorption material made of non-combustible mineral wool according to DIN 4102, shrink-wrapped or covered with acoustically transparent plastic foil. Covering of the absorption material by means of perforated plastic plate, material as housing.

Brand	: Hürner Luft- und Umwelttechnik	
Type	: HF SSD	
Connection diameter	: ...	mm
External diameter	: ...	mm
Effective length	: ...	mm
Total height	: ...	mm
Connection type	: 300 mm long pipe connection	
Attenuation	: ...	dB / 250 Hz

Design

- Sturdy welded housing with flange for fan, rain collar and roof attachment plate
- Nominal connection sizes from 110 to 400 mm, larger nominal sizes possible on request
- Roof attachment piece for flat roof, optionally available for inclined roof
- Absorption material made of non-combustible mineral wool according to DIN 4102, shrink-wrapped so it is abrasion-resistant and moisture-proof
- Made as standard from PPs material or PVC, other materials optionally available
- Two integrated cable bushings for the through-wiring of the motor connection cable and the recommended separate through-wiring of the connecting cable for frequency inverter operation or connection with PTC thermistor

HF - SSD with two cable bushings



Accessories
Silencer with two cable
bushings for
HF D ...-15 / 17 D and
HF D ...-16 D

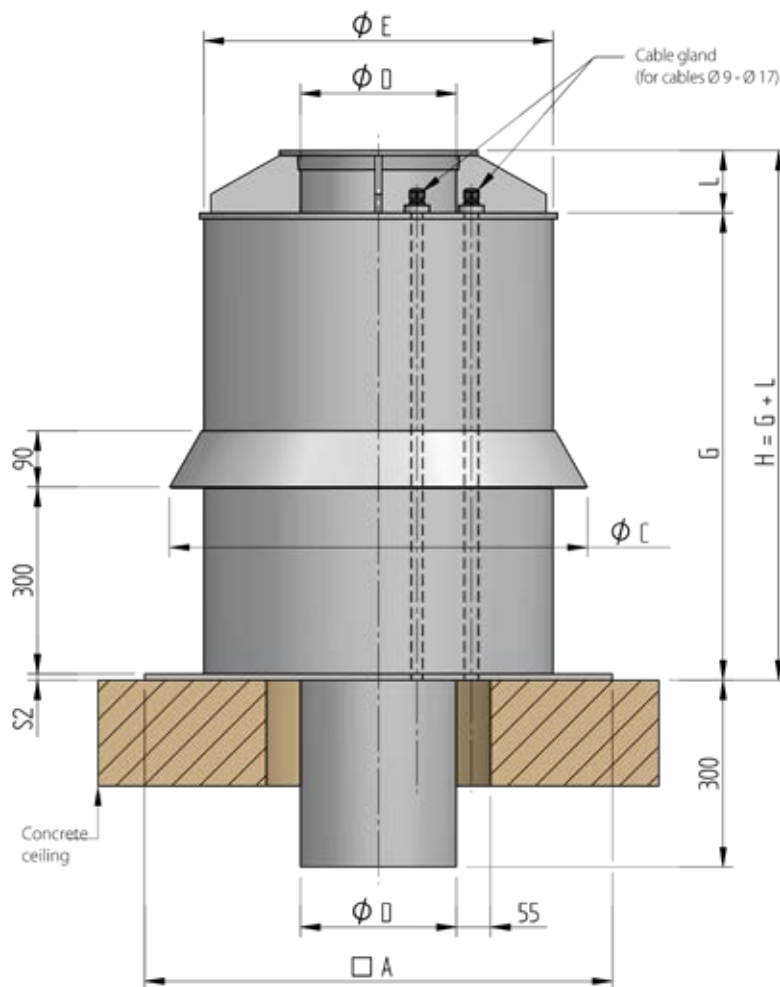

PPs									
Size - Type	Dimension [mm]					Effective length [mm]			
ϕ	$\square A$	ϕC	ϕE	$S2$	L	$G = 500$	$G = 750$	$G = 1000$	$G = 1200$
110-17	750	510	400	10	100	408-012-001000	408-012-002000	408-012-003000	
160-17	750	560	450	10	100	408-012-001100	408-012-002100	408-012-003100	408-012-004100
200-17	750	610	500	10	100	408-012-001200	408-012-002200	408-012-003200	408-012-004200
250-15	750	670	560	10	100	408-012-001300	408-012-002300	408-012-003300	408-012-004300
250-17	750	670	560	10	100	408-012-001300	408-012-002300	408-012-003300	408-012-004300
315-15	900	740	630	10	100	408-012-001400	408-012-002400	408-012-003400	408-012-004400
315-16	900	740	630	10	100	408-012-001500	408-012-002500	408-012-003500	408-012-004500
355-16	950	767	657	10	100	408-012-001600	408-012-002600	408-012-003600	408-012-004600
400-16	1000	910	800	10	100	408-012-001700	408-012-002700	408-012-003700	408-012-004700

Accessories
 Silencer for
 HF D ...-15 / 17 D and
 HF D ...-16 D

Insertion loss [dB] | Effective length $G = 500$

Size Ø	Frequency band [Hz]							
	63	125	250	500	1000	2000	4000	8000
110	7	14	26	26	26	26	18	9
160	3	7	16	18	18	18	9	4
200	2	5	13	14	14	10	5	2
250	1	4	11	11	11	7	3	1
315	1	3	9	9	9	4	2	1
355	1	3	8	8	6	3	1	1
400	1	4	7	7	5	2	1	1

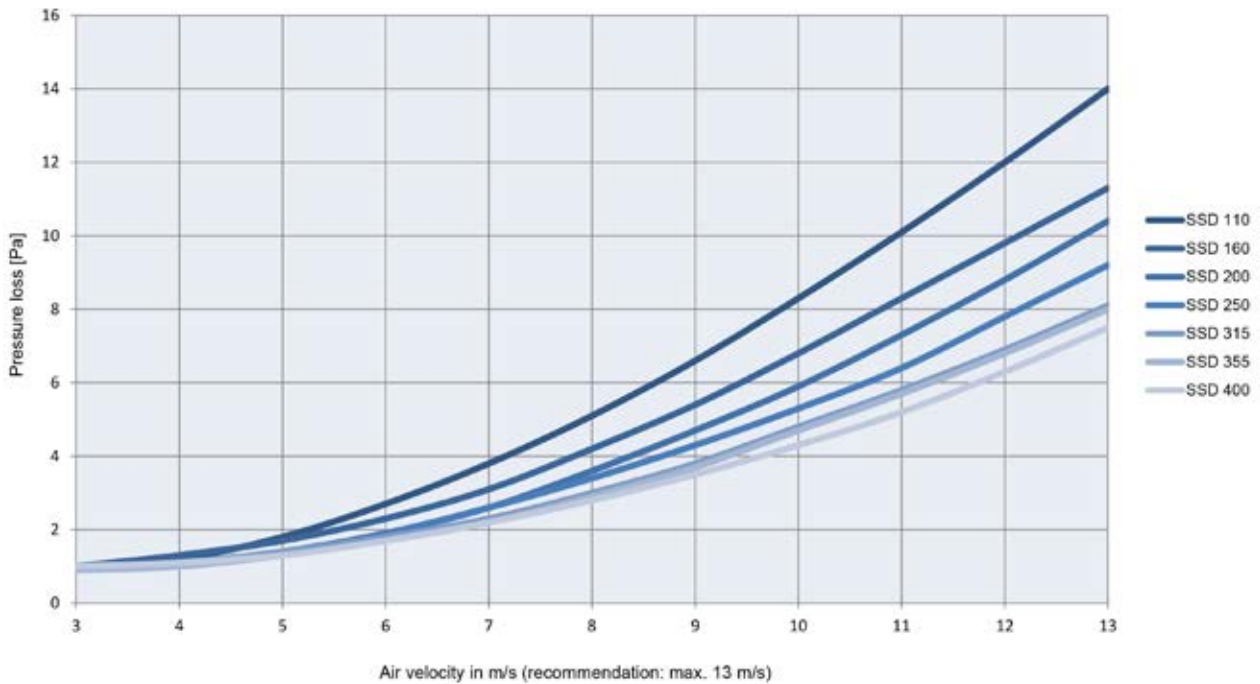
Pressure loss characteristic | Effective length $G = 500$



Accessories
 Silencer for
 HF D ...-15 / 17 D and
 HF D ...-16 D

Insertion loss [dB] | Effective length G = 750

Size Ø	Frequency band [Hz]							
	63	125	250	500	1000	2000	4000	8000
110	11	21	39	39	39	39	27	14
160	5	11	25	27	27	27	14	6
200	3	8	20	21	21	16	8	4
250	2	6	16	17	17	10	5	2
315	1	5	13	13	13	7	3	1
355	1	4	12	12	10	5	2	1
400	2	6	10	10	8	4	2	1

Pressure loss characteristic | Effective length G = 750

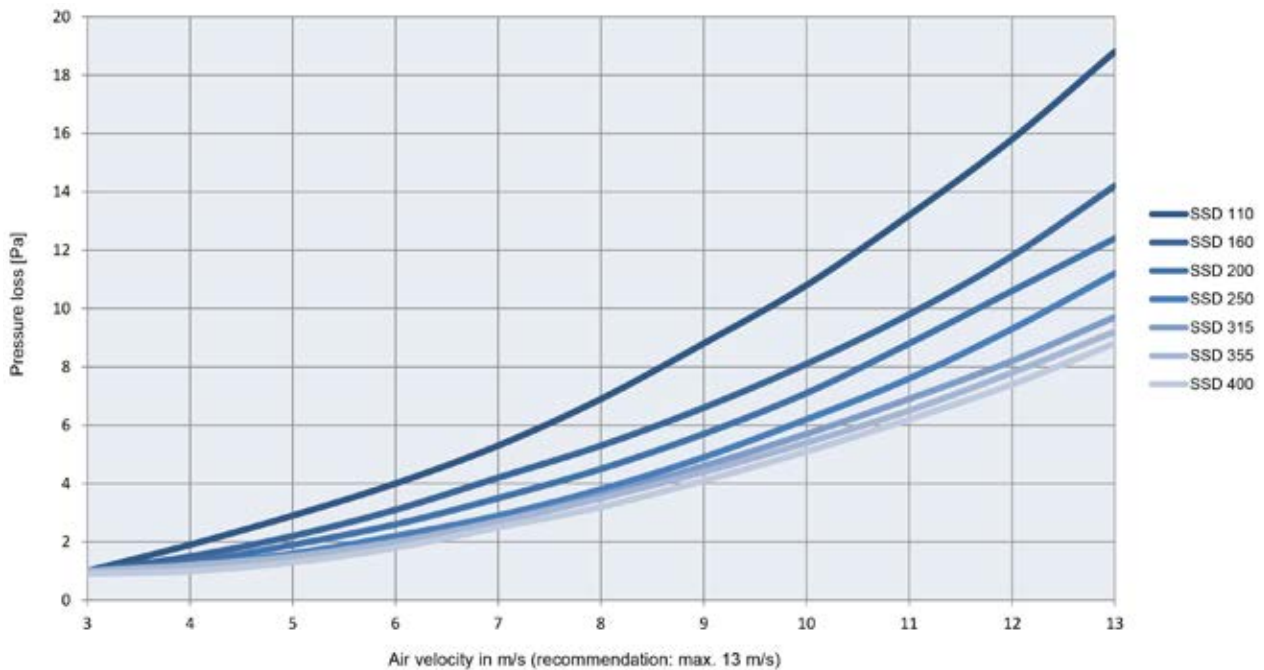

Accessories
 Silencer for
 HF D ...-15 / 17 D and
 HF D ...-16 D

Insertion loss [dB] | Effective length $G = 1000$

Size Ø	Frequency band [Hz]							
	63	125	250	500	1000	2000	4000	8000
110	15	29	50	50	50	50	36	19
160	7	15	34	36	36	36	19	9
200	4	11	27	29	29	22	11	5
250	3	8	22	23	23	14	7	3
315	2	7	18	18	18	9	4	2
355	2	6	16	16	13	7	3	1
400	3	8	14	14	10	5	2	1

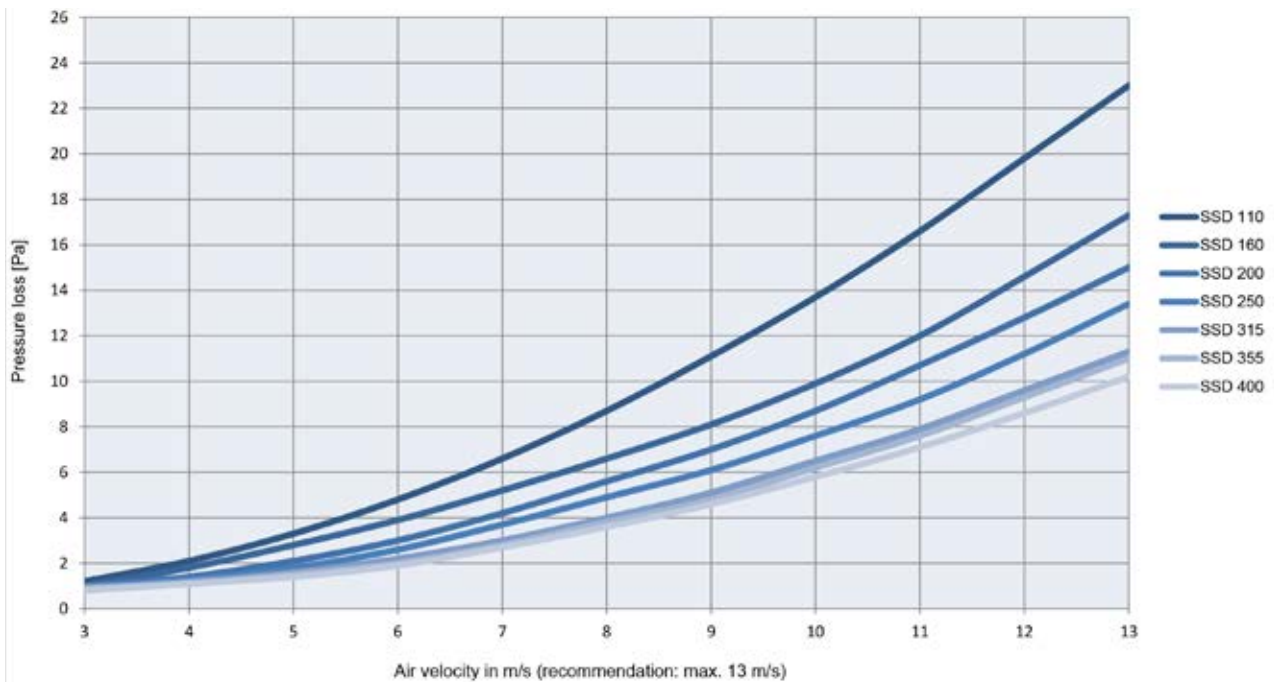
Pressure loss characteristic | Effective length $G = 1000$



Accessories
 Silencer for
 HF D ...-15 / 17 D and
 HF D ...-16 D

Insertion loss [dB] | Effective length G = 1200

Size Ø	Frequency band [Hz]							
	63	125	250	500	1000	2000	4000	8000
110	18	35	50	50	50	50	41	22
160	8	18	41	44	44	44	23	11
200	5	13	32	35	35	26	14	6
250	4	10	27	28	28	17	8	4
315	3	8	22	22	22	11	5	2
355	2	7	19	19	16	8	4	2
400	3	10	17	17	13	7	3	1

Pressure loss characteristic | Effective length G = 1200

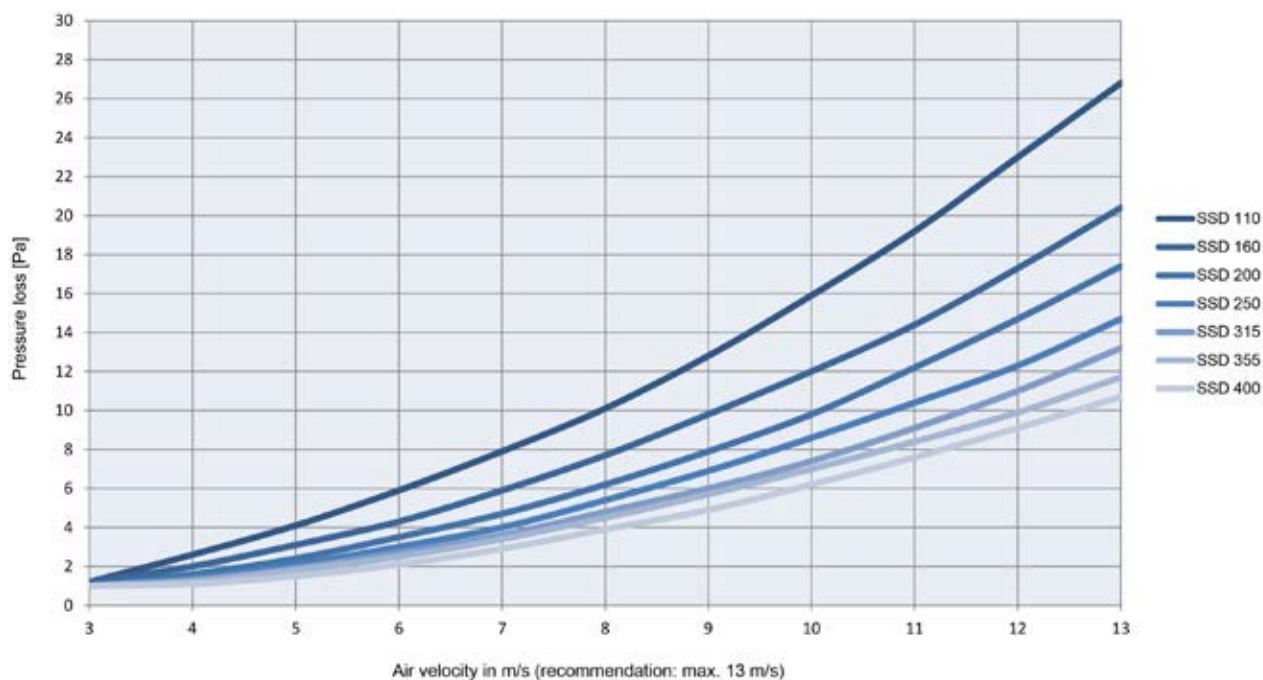

Accessories
individual
sound enclosures



Sound enclosure

Reduces the sound emission from the fan



Version in steel, galvanized:

- Frame construction with panels for easy access via turning bolt
- Suitable for outdoor installation
- Supply and exhaust air grille for self-ventilation with damped openings
- The scope of delivery includes bushings for air ducts, condensate drain, electro cables as well as lifting lugs and mounting profiles for steel construction or floor.
- Sound level reduction as standard approx. 14 dB at 250 Hz, versions for higher sound insulation requirements are available as an option

Version in plastic PP:

- Welded construction made of corrosion-resistant plastic twinwall panels access via door
- Suitable for outdoor installation
- Supply and exhaust air grille for self-ventilation with damped openings
- The scope of delivery includes bushings for air ducts, condensate drain, electro cables as well as lifting lugs and machine base.
- Sound level reduction approx. 10 dB at 250 Hz



Accessories
individual
sound enclosures

Individual sound enclosure for roof fans with outlet silencer

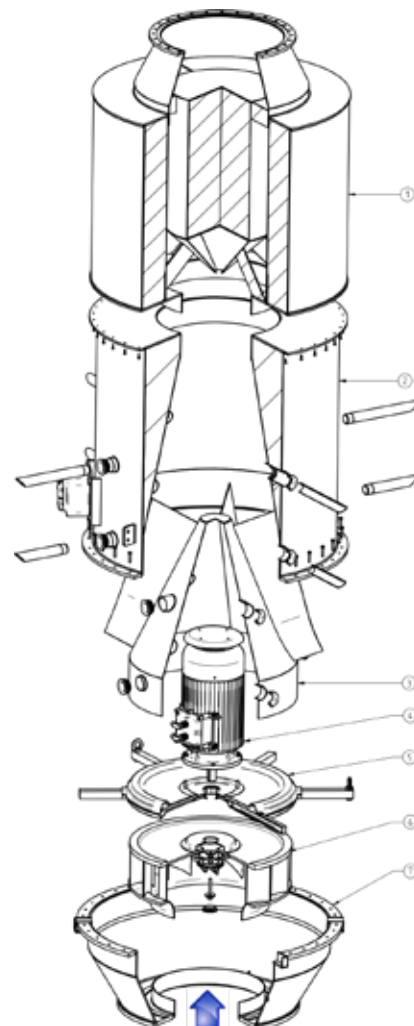

Designation		Designation	
1	Silencer	5	Support
2	Housing top	6	Impeller
3	Motor cover	7	Housing bottom
4	Motor		

Accessories

Automatic louver damper with sleeve connection on both sides for HF - roof fans



Advantages

- Made of chemically resistant plastics
- Ideal for use in aggressive exhaust air
- Prevents heat losses and contamination of laboratory equipment at low cost

Application

- Use in conjunction with exhaust air fans in the laboratory to avoid undesirable air flows when the fan is at a standstill.

Conditions of use

- Max. air velocity should not exceed 10 m/s
- Operating temperature: 0 °C to + 40 °C
- Recommended inflow route:
1 x = connection diameter in order to prevent unfavourable flow velocities and associated pressure losses

Specification

HF - louver damper

Automatic louver damper made of chemically resistant plastics, flap housing with square blade area and round sleeve connections for direct welding / bonding into the pipe, dimensionally stable blades made of PVC cavity-type profiles with free-floating mounting in the housing.

All components coming into contact with the exhaust air medium are made of chemically resistant plastics.

Brand	: Hürner Luft- und Umwelttechnik	
Type	: HF - JKS1	
Connection diameter	: ...	mm
Housing material	: PPs	
Blade material	: PVC	
Connection	: Sleeve connection	
Installation position	: vertical	

Design

- Nominal connection sizes from 110 to 500 mm
- Installation position vertically in the line
- Standard connection with round sleeves for direct welding
- Blade area square
- Blades made of rigid PVC cavity-type profiles and with free-floating mounting in the housing
- Housing made as standard from PPs material, other materials optionally available



Accessories
Automatic louver damper with sleeve connection on both sides for HF - roof fans

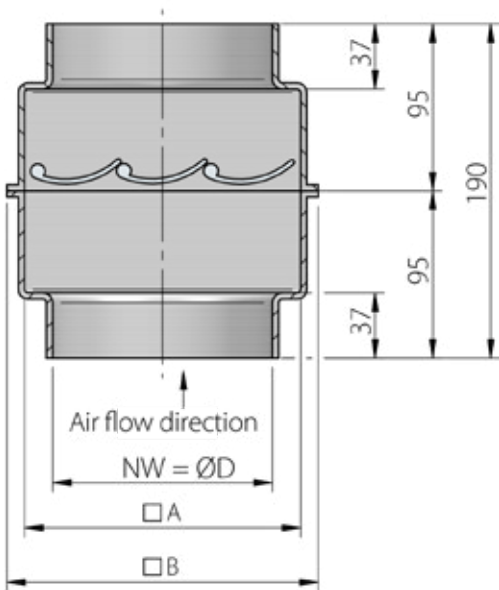

Size	Dimension [mm]		PPs Housing
	□A	B	Article no.
110	157	177	407-015-007000
160	207	227	407-015-010000
200	247	267	407-015-011000
250	250	270	407-015-012000
315	357	385	407-015-013000
355	405	435	407-015-014000
400	405	435	407-015-015000
500	560	590	407-015-016000

Other versions are optionally available.

Pressure loss characteristic

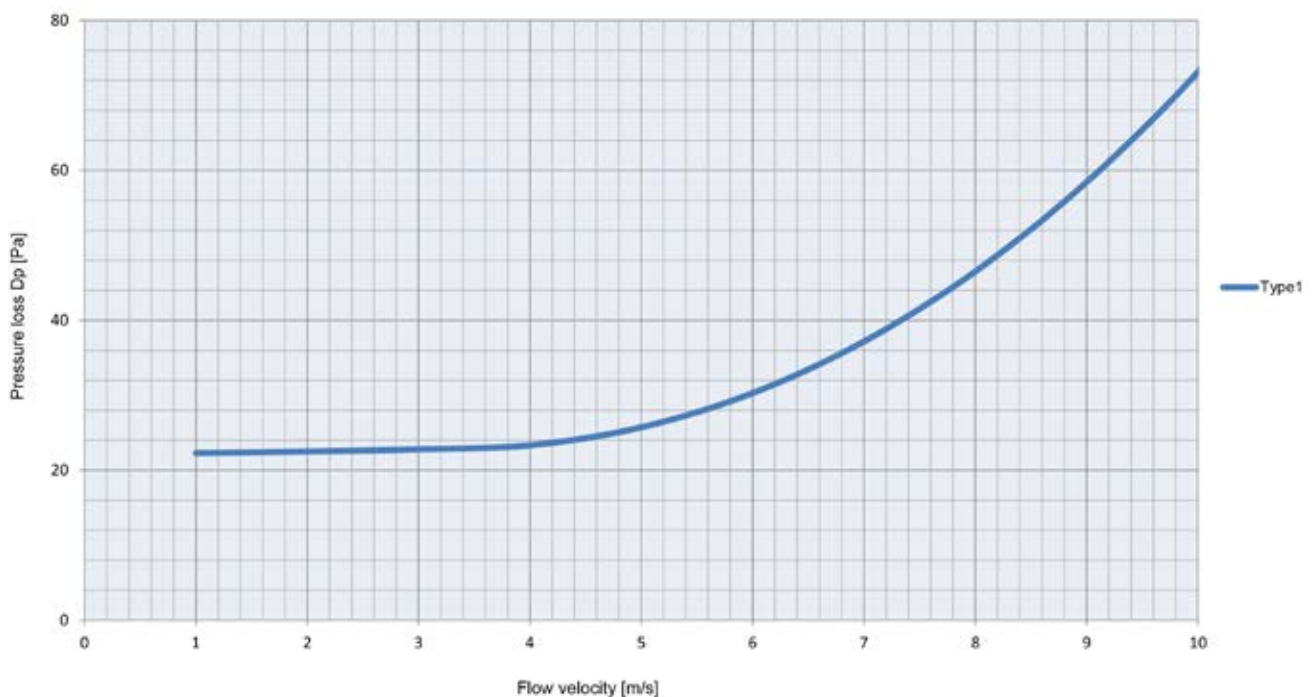

Accessories
 Adapter for HF D ...-15 / 17 D
 on existing HF D ...-16 D
 roof attachment



Application

- Installation of roof fans of the HF ...-15 / 17 D series on a flange of the HF D ...-16 D series

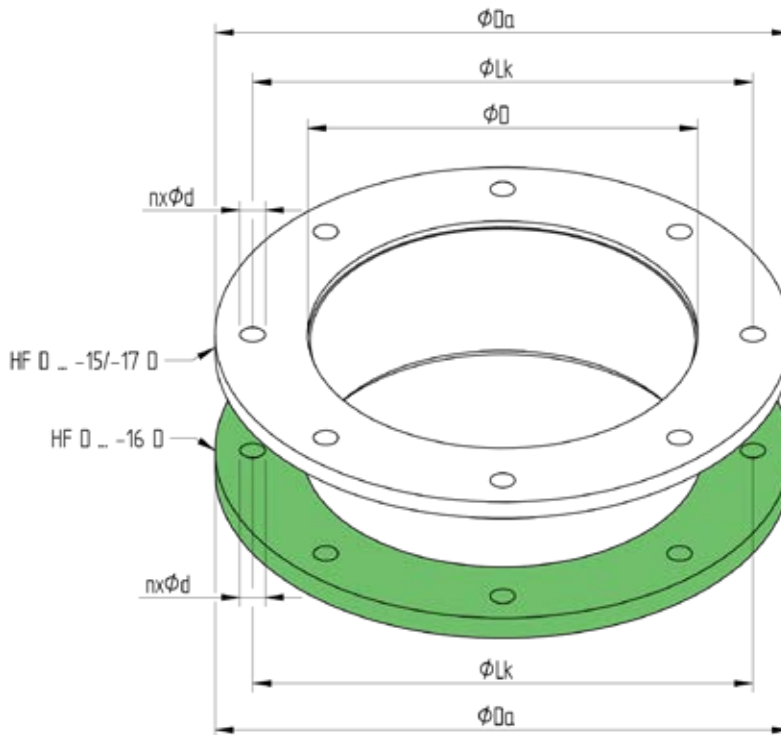

Adapters for fan type HF D ... -15 / -17 D					on existing roof attachment type HF D ... -16 D					PPs
Size - Type	Dimensions [mm]				Size - Type	Dimensions [mm]				
Ø	ØDa	ØLk	n	Ød	Ø	ØDa	ØLk	n	Ød	Article no.
160-17	230	200	8	10	160-16	280	210	8	9,5	415-018-000700
200-17	270	240	8	10	200-16	280	250	8	9,5	415-018-001300
250-15	320	290	12	10	250-16	340	300	12	9,5	415-018-001900
250-17	320	290	12	10	250-16	340	300	12	9,5	415-018-001900
315-15	380	350	12	10	315-16	410	365	12	9,5	415-018-002500

Installation height for all variants 60 mm



Accessories
Adapter for
HF D ...-15 / 17 D on
existing roof attachment

Application

- Installation of roof fans of the HF D ...-15 / 17 D series onto an existing flange.

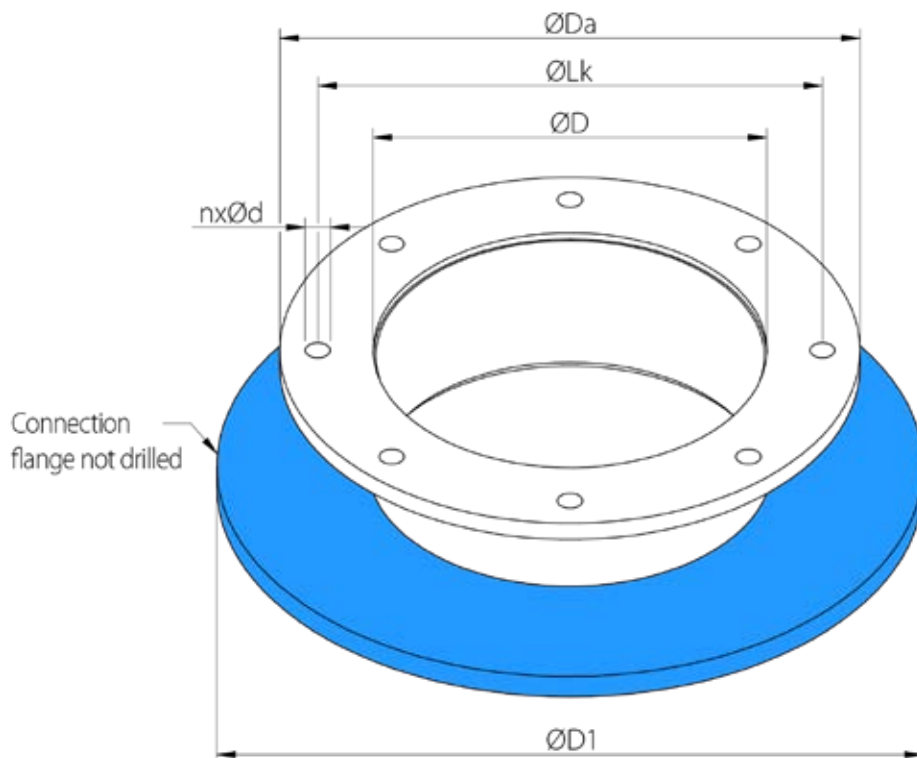

Installation of roof attachment provided by customer onto fan type HF D ... -15 / -17 D								
Size - Type	Dimensions [mm]						PVC	PPs
Ø	ØDa	ØLk	ØD	n	Ød	ØD1	Article no.	Article no.
110-17	170	150	110	8	10	230	415-008-000100	415-018-000100
160-17	230	200	160	8	10	280	415-008-000400	415-018-000400
200-17	270	240	200	8	10	320	415-008-001000	415-018-001000
250-15	320	290	250	12	10	370	415-008-001600	415-018-001600
250-17	320	290	250	12	10	370	415-008-001600	415-018-001600
315-15	380	350	315	12	10	435	415-008-002200	415-018-002200

Installation height for all variants 60 mm

Other versions optionally available.

Accessories
for horizontal mounting of
HF D ...-15 / 17 D and
HF D ...-16 D

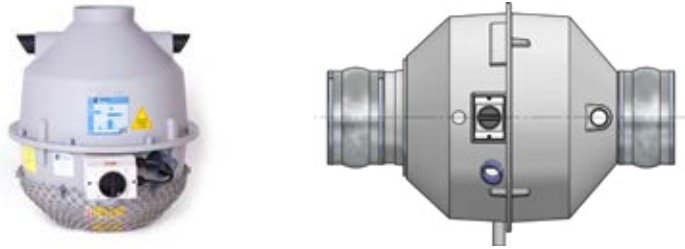

Horizontal mounting

Size - Type	Horizontal mounting
Ø	Article no.
110-17	441-080-110000
160-17	441-080-160000
200-17	441-080-200000
250-15	441-080-250000
250-17	441-080-250000
315-15	441-080-315000
160-16	441-080-160007
200-16	441-080-200016
250-16	441-080-250016
315-16	441-080-315002
355-16	441-080-355000
400-16	441-080-400000



The intake-side adapters for HF - roof fans of the HF D ...-15 / 17 D series are made of the material PPs as standard.

For the horizontal mounting of the HF D 160-16 D, HF D 200-16 D and HF D 250-16 D roof fans, the intake-side adapters are made of the material PPs-el as standard.

Other versions are optionally available.

Depending on the size of the fan and its installation position, an on-site support should be provided.

Floor mounting feet

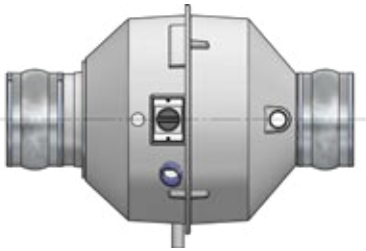

Accessories
for horizontal
floor mounting of
HF D ...-15 / 17 D

Floor mounting feet

For easy horizontal mounting

Size- Type	Floor mounting feet
Ø	Article no.
110-17	441-011-000111
160-17	441-011-000161
200-17	441-011-000201
250-15	441-011-000251
250-17	441-011-000252
315-15	441-011-000315



Installation feet for the horizontal mounting of HF roof fans of the HF D ...-16 D series are optionally available.

Accessories for HF - roof fans



Shaft seal felt ring

Protects against leakage at the shaft passage



Size - Type	Felt ring
Ø	Article no.
110-17	441-040-D00000
160-17	441-040-D00001
200-17	441-040-D00001
250-15	441-040-D00001
250-17	441-040-D00001
315-15	441-040-D00001

Series HF D ...-16 D and HF D ...-13 D fitted as standard with felt ring seal on the shaft bushing.

Protection grid

Protects against foreign bodies

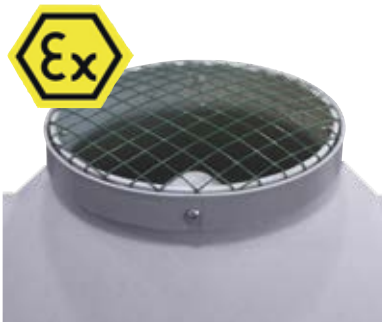

Size - Type	Inlet side loose	Outlet side installed PPs	Outlet side installed PPs-el
Ø	Article no.	Article no.	Article no.
110-17	441-022-110000	441-023-110000	
160-17	441-022-160000	441-023-160000	
200-17	441-022-200000	441-023-200000	
250-15	441-022-250000	441-023-250000	
250-17	441-022-250000	441-023-250000	
315-15	441-022-315000	441-023-315000	
160-16	441-022-160001		441-023-160002
200-16	441-022-200001	441-023-200003	441-023-200001
250-16	441-022-250001	441-023-250002	441-023-250001
315-16	441-022-315001	441-023-315001	441-023-315002
355-16	441-022-355000	441-023-355000	441-023-355001
400-16	441-022-400001	441-023-400001	441-023-400002
500-13	441-022-500001	441-023-500003	441-023-500002
560-13	441-022-560001	441-023-560001	441-023-560002
630-13	441-022-630001	441-023-630005	441-023-630003
800-13	441-022-800000	441-023-800000	441-023-800001
1000-13	441-022-100000	441-023-100000	441-023-100001

Accessories



Accessories for
HF - roof fans
repair switch | Connecting
diagram

Connecting diagram for standard three-phase motor

Motor cable		Switch Y (400 V)				Switch Δ (230 V)			
Cable no.	Winding	Pin	Motor cable no.	Mains	Pin	Motor cable no.	Mains		
1	U1	L1	-	(L1)	L1	-	(L1)		
2	V1	L2	-	(L2)	L2	-	(L2)		
3	W1	L3	-	(L3)	L3	-	(L3)		
4	U2	T1	1 (U1)	-	T1	1 (U1) + 6 (W2)			
5	V2	T2	2 (V1)	-	T2	2 (V1) + 4 (U2)			
6	W2	T3	3 (W1)	-	T3	3 (W1) + 5 (V2)			
7	PTC	Y-jumper {							
8	PTC	4 (U2)							
		5 (V2)							
		6 (W2)							

Connection diagram for motors with two speeds | separate winding

Motor cable		Connections at repair switch					
Cable no.	Winding	Switch pins			Motor cable no.		
1	U1	on-site connection 380 V 3-phase	← L1	T1 →	1 (U1)	} low speed	
2	V1		← L2	T2 →	2 (V1)		
3	W1		← L3	T3 →	3 (W1)		
4	U2		← 2L1	2T1 →	4 (U2)	} high speed	
5	V2		← 2L2	2T2 →	5 (V2)		
6	W2		← 2L3	2T3 →	6 (W2)		
7	PTC						
8	PTC						

Connection diagram for motors with two speeds | Dahlander pole changing motor

Motor cable		Connections at repair switch					
Cable no.	Winding	Switch pins			Motor cable no.		
1	U1	on-site connection 380 V 3-phase	← L1	T1 →	1 (U1)	} low speed	
2	V1		← L2	T2 →	2 (V1)		
3	W1		← L3	T3 →	3 (W1)		
4	U2		← 2L1	2T1 →	4 (U2)	} high speed U1 - V1 - W1 must be star connected	
5	V2		← 2L2	2T2 →	5 (V2)		
6	W2		← 2L3	2T3 →	6 (W2)		
7	PTC						
8	PTC						

ATEX 2014/34/EU

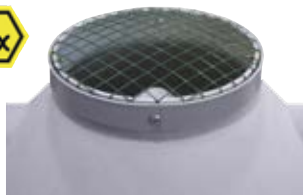

Protection grid



Shaft seal felt ring

HLU fans according to ATEX 2014/34/EU

The ATEX Directive 2014/34/EU regulates the requirements with regard to placing products on the market that are used in potentially explosive atmospheres. The term ATEX is derived from the French abbreviation "Atmosphère explosible" and is used as a synonym for the two directives of the

European Community in the area of explosion protection, ATEX Directive 2014/34/EU and ATEX Directive 1999/92/EG. The design of fans in the ATEX area is described in detail in the norms DIN EN 14986 and DIN EN ISO 80079.

Explosion protection is differentiated according to the conveyed atmosphere (inside) and the surroundings of the installation site (outside).

HLU supplies fans for the ATEX Zones 2 and 1 for different zone combinations.

inside	outside
Zone 1	Zone 1
Zone 1	Zone 2
Zone 2	Zone 2
Zone 2	no Zone

HF - roof fan in ATEX version – for Zone 2 inside / no Zone outside:

Optional suction- and pressure-side protective grid to protect against contaminants

Shaft seal felt ring

Type plate with Ex-labelling and documentation

Housing and Impeller in flame-retardant plastic (PEs, PPs, PVC, ...)



HF - roof fan in ATEX version – for Zone 2 inside / Zone 2 outside:

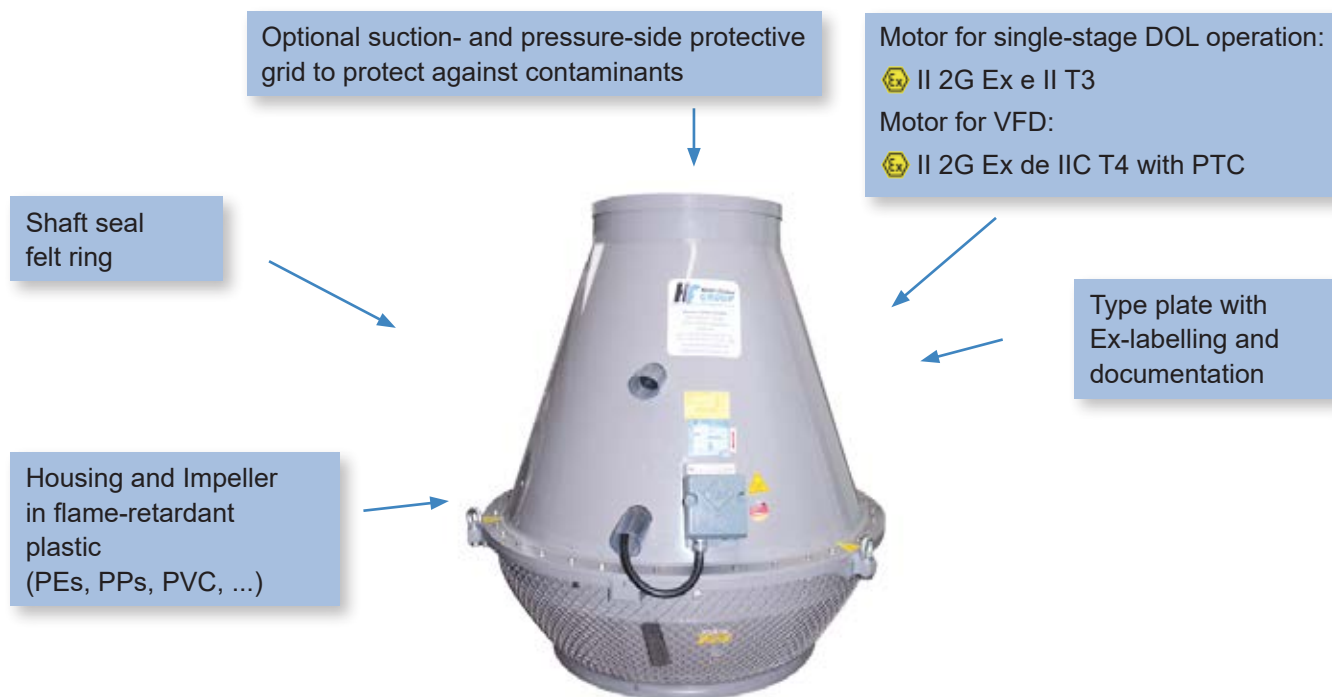

HF - roof fan in ATEX version – for Zone 1 inside / Zone 2 outside: – for Zone 1 inside / Zone 1 outside:

HLU fans for ATEX Zone 1 are made of electrical conductive plastics (el).

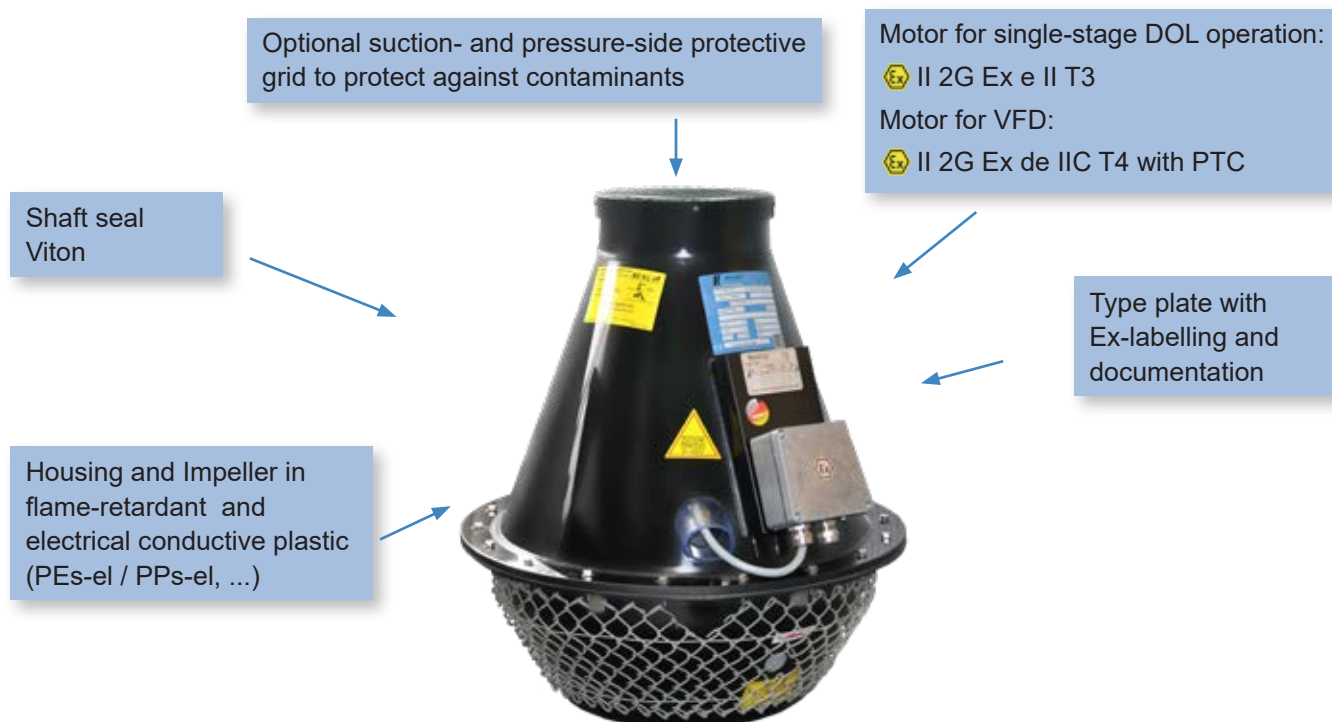

ATEX 2014/34/EU

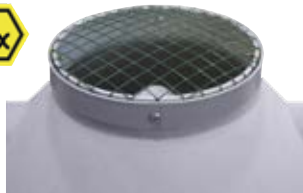

Protection grid



Shaft seal felt ring

You will see on the fan's type plate a permanent identification of the explosion protection. The following illustration explains the labelling of equipment for potentially explosive atmospheres:

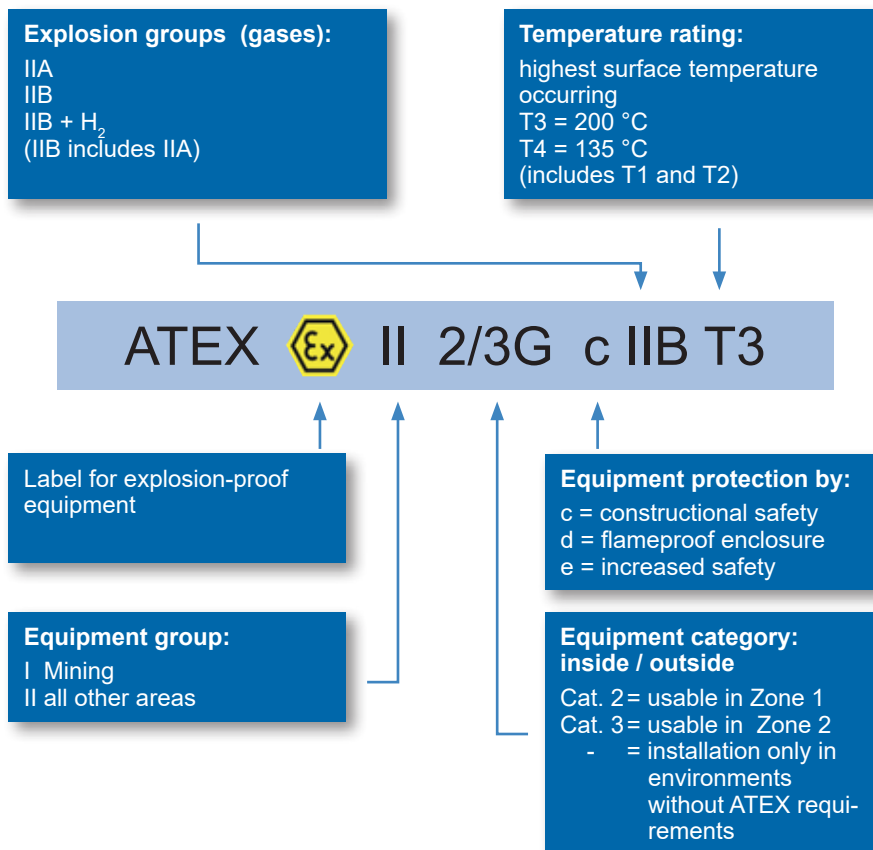

The operator of a facility is obligated to conduct a risk assessment. For questions regarding the Zone classification, you can contact various test centres such as for example safety engineers and special consultants. The following tables serve as reference:

An explosive gas atmosphere exists ...	ATEX Ex Zone	ATEX Device category	IEC EPL	(International) (Equipment Protection Level)
for more than 30 min. per year, however, less than 50% of the operational period daily	Zone 1	Category 2G		Gb
for a max. of 30 min. in a year	Zone 2	Category 3G		Gc

Why plastic?

- Durable ■
- Corrosion resistant ■
- Resistant to chemicals ■
- High ductility ■
- Wide spectrum of materials ■

www.hlu.eu





Hürner Luft- und Umwelttechnik

www.hlu.eu

Hürner Luft- und Umwelttechnik GmbH
Ernst-Hürner-Straße
35325 Mücke-Atzenhain
Germany

Tel + 49 6401 9180 - 0
Fax + 49 6401 9180 - 142

info@hlu.eu

HLU Systemtechnik GmbH
Sälzerstraße 20a
56235 Ransbach-Baumbach
Germany

Tel + 49 2623 92 95 9 - 0
Fax + 49 2623 92 95 9 - 99

systemtechnik@hlu.eu

Edition 10/2018