

UNBALANCE VIBRATOR

JV ... / JVA...

Series 28

Manufacturer: JVM Antriebe GmbH + Co. KG, 48249 Dülmen
Internet: www.j-vm.com

Table of content

1. SAFETY	3
1.1. WORK SAFETY SYMBOL.....	3
1.2. 'ATTENTION' NOTICE	3
1.3. GENERAL WORK SAFETY AND 'ATTENTION' INSTRUCTIONS FOR UNBALANCE VIBRATORS	3
2. GENERAL NOTES	4
3. DESIGN AND OPERATION	4
3.1. GENERAL.....	4
3.2. DESIGN OF AN UNBALANCE VIBRATOR	4
3.3. OPERATIONAL CHARACTERISTICS	5
3.4. NOISE INFORMATION (ACCORDING TO 3. GSGV).....	5
3.5. RATING PLATES.....	5
4. STORAGE.....	6
5. HANDLING	6
6. INSTALLATION	7
7. ELECTRICAL CONNECTION	8
8. SETTING THE CENTRIFUGAL FORCE.....	12
8.1. SAFETY NOTE.....	12
8.2. SETTING INSTRUCTIONS.....	12
9. MAINTENANCE.....	14
9.1. IMPORTANT NOTES	14
9.2. LUBRICATION	14
9.3. OTHER MAINTENANCE / INSPECTION OPERATIONS.....	15
10. SPARE PARTS	16
10.1. IMPORTANT NOTES.....	16
10.2. SPARE PARTS DRAWING/PARTS LIST.....	16
11. SPECIAL DESIGNS.....	17
11.1. PTC RESISTOR AS ADDITIONAL PROTECTION	17
11.2. POLE REVERSING UNBALANCE VIBRATOR.....	17
12. DATA FOR NORMALS MAINS CONNECTION AND CONNECTION UNDER EMC CONDITIONS	18
13. DATA SHEET.....	18

1. Safety

1.1. Work safety symbol



This symbol is in this operating manual allocated to those safety instructions which deal with danger to the health and life of persons.

These instructions must be strictly observed. Please pass this document to the operators of the unbalance vibrator.

Apart from the work safety instructions in this operating manual, the general as well as the local safety and accident prevention regulations must be observed.

1.2. 'Attention' notice

ATTENTION

This symbol is in this operating manual allocated to those notes, regulations and guidelines which deal with damage to or destruction of the unbalance vibrator as a result of inexpert operation.

1.3. General work safety and 'attention' instructions for unbalance vibrators

It must be ensured that every person charged with the installation, operation and maintenance of the unbalance vibrator has read and understood this operating manual before commencing work.

The unbalance vibrator has been built in accordance with the latest state of technology and is safe and reliable. If, however, it is inexpertly operated by uninstructed persons, it may cause grave injury and damage.

The unbalance vibrator is intended exclusively for the application agreed with the manufacturer. If this is not observed, the manufacturer will not accept liability for any resulting damage or injury.

For the installation, electrical connection, setting of centrifugal force and maintenance, it must be made clear which person is responsible for the work, so that safety is not impaired when working with the unbalance vibrator.

The unbalance vibrator must only be operated in its original condition, except for the setting of centrifugal force. If changes from the original condition are found, these must be reported by the operator to the appropriate office.

Conversions and alterations of the unbalance vibrator on the operator's own initiative, which could impair the safety, are not permitted.



All maintenance and setting work on the unbalance vibrator must in principle only be carried at rest. Before starting work, ensure that the unbalance vibrator cannot be switched on accidentally or by unauthorized persons.

The unbalance vibrator must never be operated without the covers of the centrifugal weights. Danger of injury!

The electrical connection of the unbalance vibrator must be adequately fused..

If the insulation of the connection cable is damaged or if the cover of the terminal box is missing, there is a life-threatening danger of electrocution! Such defects must be corrected immediately!

In areas which are subject to explosion risk, only explosion-proof unbalance vibrators must be used. This is indicated as such by the type of explosion-proof enclosure shown in the rating plate as well as by the EX symbol on the housing of the unbalance vibrator. In addition, the special requirements of this operating manual for safe use must be observed.



2. General notes

Only with the aid of this operating manual it is possible to install, set, operate and maintain the unbalance vibrator properly and safely.

The manufacturer recommends that the operating manual is read through carefully, since he does not accept liability for damage resulting from non-observance of this operating manual.

The operating manual should always be kept ready to hand for the operator.

Changes in design and construction, for the purpose of improving the unbalance vibrator, are reserved.

The characteristics power consumption [kW], rated current [A], rated voltage [V], working moment [kgcm] and rated speed [1/min] are given on the rating plate or type plate of the drive.

3. Design and operation

3.1. General

The unbalance vibrator generates the vibratory motions by means of rotary centrifugal weights.

3.2. Design of an unbalance vibrator

A type JVJVA unbalance vibrator type 28 consists of the following main elements:

1. Stator
2. Endshield with bearing
3. Rotor
4. Centrifugal weights
5. Cover

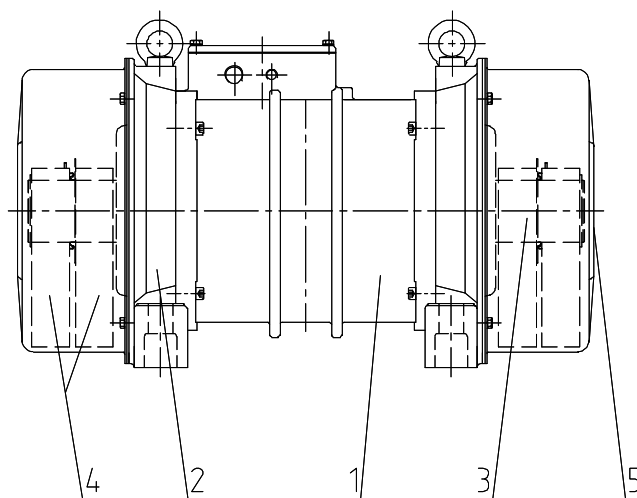

3.3. Operational characteristics

The unbalance vibrator is a three-phase squirrel-cage motor. The two shaft extensions of the rotor, which is mounted in antifriction bearings, carry adjustable centrifugal weights.

With the unbalance vibrator switched on, the rotary motion of the rotor and its centrifugal weights generates a centrifugal force. This causes the machine connected to the unbalance vibrator to vibrate.

Type N unbalance vibrators are in principle designed for continuous duty in accordance with S1 to VDE 0530.

3.4. Noise information (according to 3. GSGV)

The sound pressure level can be taken from the data sheet of the unbalance motor.





The sound pressure level - at nominal speed and operating temperature has been determined on a testing stand by the manufacturer.

3.5. Rating plates

The unbalance vibrator JV is identified by the following rating plate:

JOST [®] Gewerbestraße 28-32 48249 Dülmen - Germany			
CE	Type	P ₁	kW/IP
⊕	Torque	kgcm	M-No.
3~	Mot.	V	A Hz
cos φ	T-No.	Year	
	/min	therm. cl.	DIN EN 60034-1

The unbalance vibrator JVA is identified by the following rating plate:

				Gewerbestraße 28-32 48249 Dülmen - Germany			
CE				ATEX II 3G+D		T4/T120	
		Trq.		kgcm		P ₁ kW 	
3~Mot.		V		A		Hz	
cos φ		M-No.		Yr.			
IP		/min		therm. cl.		DIN EN 60034-1	

4. Storage

Until its final installation, the unbalance vibrator should as far as possible be stored in closed rooms.

If the unbalance vibrator is stored in the open, it must be covered with tarpaulins open underneath, so that any condensate can drain off. In the case seaworthy packing of the unbalance vibrator, this packing must not be damaged or opened during transit and storage

The unbalance vibrator must be placed on a suitable base to counteract ground moisture or it must be stored in shelves.

The unbalance vibrator must only be placed on its foot surfaces!

ATTENTION

To protect against corrosion, the foot surfaces are greased before dispatch from the works. This grease coating must only be removed immediately before installation..

5. Handling

To avoid danger to persons and damage of the unbalance vibrator, the unbalance vibrator must be handled with proper care! Apart from the instructions below, the general as well as the local safety and accident prevention regulations must be observed.



If the unbalance vibrator is packaged, the handling gear must only be attached at the points marked. The symbols for handling - if any - have to be observed:



Hitch here!



Centre of gravity!



UP!

The unbalance vibrator itself must only be carried at the hitching eyes provided at the stator. Small unbalance vibrators must be carried by using a rope fixed at the stator.



The unbalance vibrator must only be placed on its foot surfaces!

ATTENTION

Transit damage must always be reported to the manufacturer. Care has to be taken that the foot surfaces and covers are in a non-damaged condition.

ATTENTION

6. Installation

The unbalance vibrator must be installed by qualified personnel. The manufacturer does not accept any responsibility for faulty installation!

ATTENTION

The foot support surfaces of the unbalance vibrator must be metallically bright and free from grease, paint or other impurities.

The support surfaces for the unbalance vibrator on the machine must be plane parallel, have a maximum peak-to-valley height of R_z 25 μm and be metallically bright as well as being free from dirt and grease.

The machine part on which the unbalance motor is mounted (e. g. motor cross-member, motor base plate), must be sufficiently strong, to eliminate the possibility of deformation (bending, torsion) between the foot contact surfaces of the unbalance vibrator as a result of the occurring centrifugal forces. The unbalance vibrator is not a load-bearing component!

ATTENTION

Unbalanced mass vibration generator	Thread	Torque MA (Nm)
JV/ JVA 28	M 30	1450

The thread size of the fixing screws, of quality class 8.8, and the required tightening torques are given in the above table. Self-locking nuts of quality class 8 must be used. One washer according to DIN 125, made at least of St-50, must be placed under the screw head and nut.

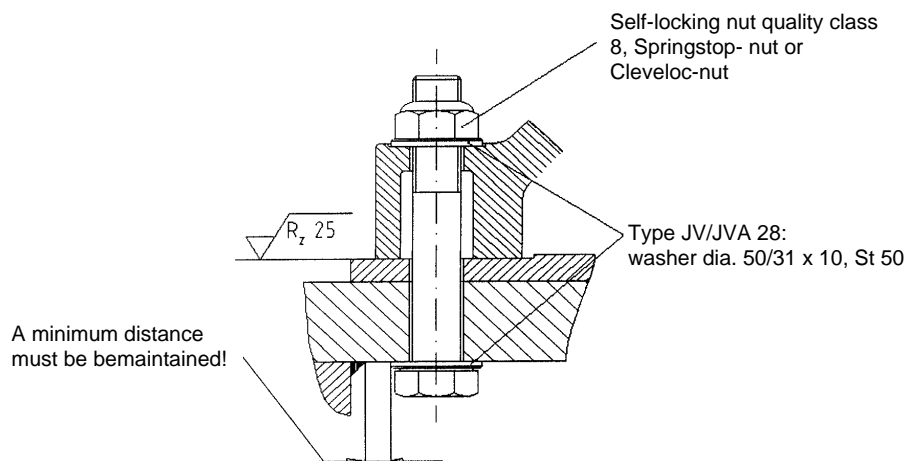

After the first 50 hours of operation the unbalance vibrator, the fixing screws must be retightened to the correct tightening torque.

ATTENTION

The centrifugal weights of an unbalance vibrator must be set identically at both sides. The setting can be read off with % - scales provided on the centrifugal weights.

ATTENTION

If a vibratory machine is driven by two unbalance vibrators, the centrifugal weights must on the two unbalance vibrators be set to the same %-value. With an unequal setting, damaging transverse vibrations will occur on the vibratory machine.

ATTENTION

If an unbalance vibrator is replaced, the uniformity of the setting of the centrifugal weights of the two unbalance vibrators must be checked and if necessary established before starting up.

7. Electrical connection

Electrical connection of unbalanced mass vibration generators should be carried out only by authorised persons who have been suitably trained. When making the electrical connection of the unbalanced mass vibration generator the (German) VDE 0100 and VDE 0113 regulations must be observed. If the unbalanced mass vibration generator is to be exported the electrical regulations of the respective country are to be observed.



For the JVA unbalanced mass vibration generator the regulations of the (German) „Directive for Electrical Equipment in Potentially Explosive Areas (Elex V)” generally apply. For installation of electrical equipment in areas endangered through potential gas explosion “IEC 60070.14” applies and in areas endangered through potential dust explosions “IEC 61421-1 and –2” are applicable.

If the unbalance vibrator is equipped with a PTC thermistor (130°), the auxilliary line can be connected to a trigger device in order to protect the drive thermally, for example thermistor protective relay for PTC thermistor – temperature sensor (Siemens 3 RN 1010-1CM00 control voltage 230V AC).

Before electrically connecting the unbalanced mass vibration generator the existing mains voltage and frequency should be compared with the values given on the rating plate of the unbalanced mass vibration generator. Correct connection of the terminals in the terminal box should be checked (see circuit diagram in the terminal box).



For JV unbalanced mass vibration generators fluctuations in voltage of the power supply of more than +/- 10% are not permissible.

For JVA unbalanced mass vibration generators voltage fluctuations of only +/- 5% are permissible.

In order to guarantee a reliable start of the unbalanced mass vibration generator it should only be switched on directly.

ATTENTION

The unbalanced mass vibration generator must be connected only to a three-phase supply network with a protective conductor. The protective conductor of the three-phase supply network must be connected to the corresponding terminal provided in the terminal box.

The unbalanced mass vibration generators are wired internally in such a way that with the same connection of phases L1-L2-L3 to terminals U1-V1-W1 this gives the same direction of rotation for all unbalanced mass vibration generators – from the same viewpoint looking towards the cable entry.

If the drive of a vibrating machine consists of two unbalanced mass vibration generators these should be connected in such a way that their direction of rotation is opposed. To achieve this both unbalanced mass vibration generators must be connected in the same order $L_1-L_2-L_3 \Rightarrow U_1-V_1-W_1$. The arrangement on the vibrating machine from a viewpoint looking towards the protective cover and cable entries must be mirror-inverted (see diagram on page 10).



ATTENTION

Terminal diagramm

Y-circuit terminal box

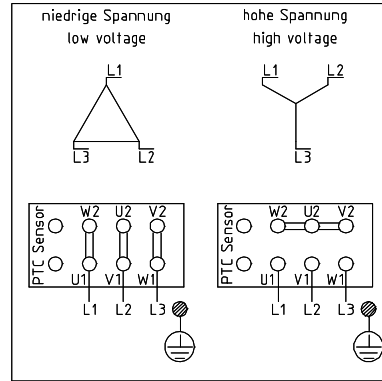
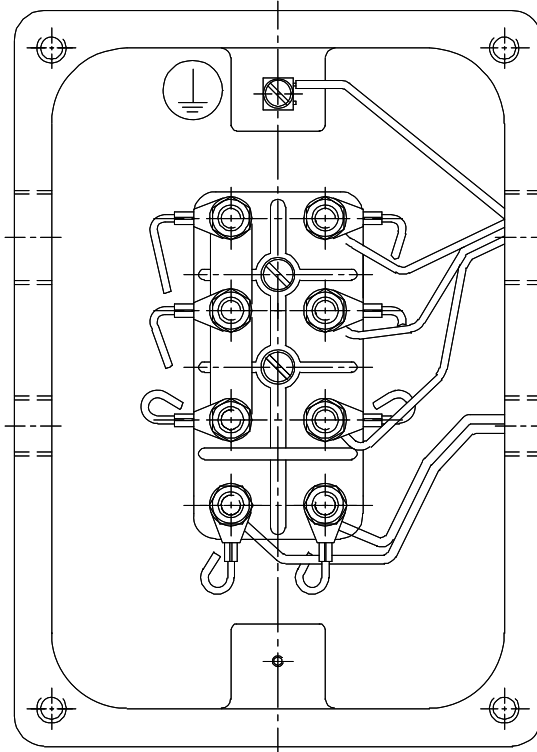

Δ - circuit terminal box

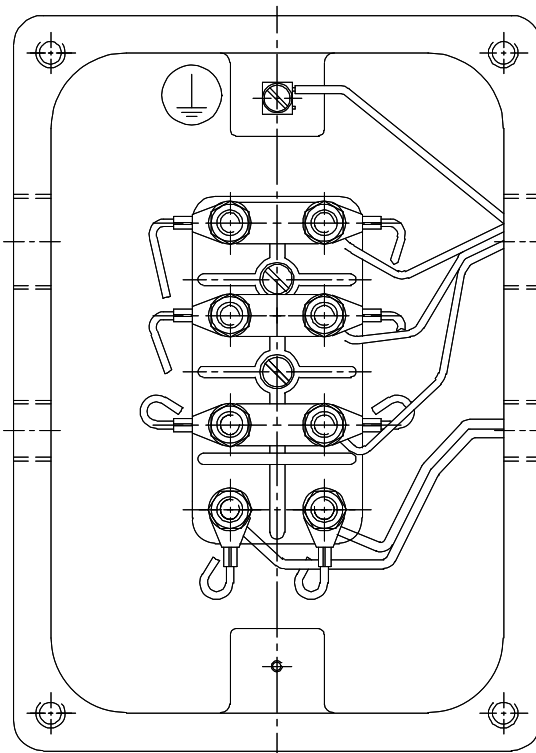

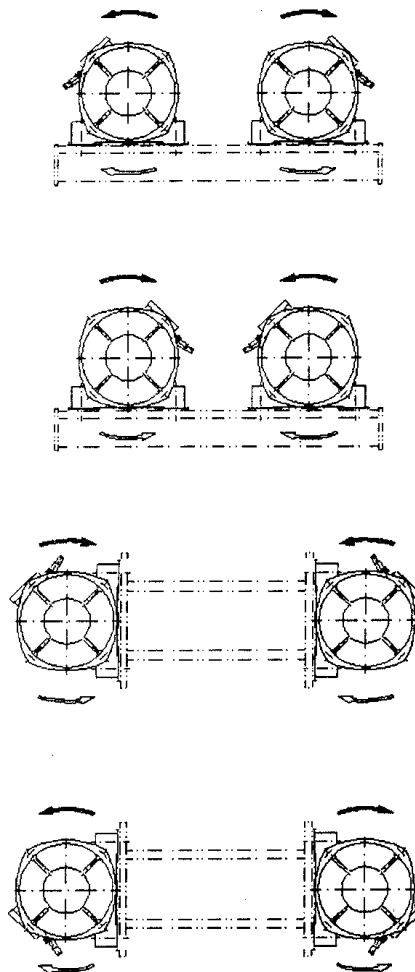

Before starting up the vibrating machine the correct **opposed** direction of rotation of the unbalanced mass vibration generators must be checked, as follows:

With the vibrating machine switched off and secured against unauthorised switching on, one protective cover of each of the unbalanced mass vibration generators is to be removed. Then when the unbalanced mass vibration generators are switched on briefly (approx. 2 – 3 secs) the direction of rotation can be seen. This should be counter-rotating.

Caution! Danger of injury through rotating unbalanced masses.

If the direction of rotation is not counter-rotating the poles of one of the two unbalanced mass vibration generators must be reversed. With the unbalanced mass vibration generators switched off and secured against unauthorised switching on, the protective covers should then be refitted.

Check with the vibrating machine running. The direction of vibration – as seen in the direction of conveyance – must be linear.

In exceptional cases (spiral conveyor, special machines) the unbalanced mass vibration generators run in the same direction. For this the arrangement of the unbalanced mass vibration generators on the machine – from a viewpoint looking towards the protective cover and cable entries, and with the same electrical connection – must be the same as in the following diagram.



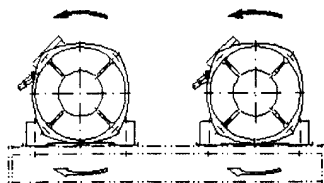

For the connection a highly elastic, mechanically robust hose line is to be provided as connecting line between the unbalanced mass vibration generator and the first distribution box. This should have a temperature resistance of at least 90°C. The minimum required nominal cross-section according to DIN 57100, part 523, and the connection cross-section for guaranteeing reliable operation are given in the data sheet of the unbalanced mass vibration generator.

In the terminal box the individual conductors should be led from the cable entry to the terminal board over as short a distance as possible in order to avoid damage to the conductors through vibration. The hose line should be secured against twisting and pulling in the cable entry. At the same time care should be taken that the hose line outside diameter is correct (for inside diameter of the cable gland see data sheet).

For control of the vibration by means of a frequency converter a shielded cable is required as connecting cable between the vibrator and frequency converter, in accordance with the conditions of the EMC (German Electromagnetic Compatibility) law. Vibrators of the type JV are suitable for connection under EMC conditions.

For connecting the required shielded cable the existing standard cable gland must be removed by the customer and replaced by a suitable cable gland, e.g. type SHVE.

ATTENTION

Recommendations for suitable cable glands and sizes of shielded cable are given in the table „Connection Data”, in section 12. It should be noted that allocations of diameters of cables (inside and outside diameter) and cable gland (sealing cone and sleeve) are subject to narrow tolerances.

ATTENTION

After connecting the supply cable the terminal box cover should be replaced. In doing so care should be taken that the rubber seal fits correctly. The fixing screws should be firmly tightened.

The supply cable of every unbalanced mass vibration generator must sag freely between the first fixed point and the unbalanced mass vibration generator, to such an extent that there is no tension of the cable in the starting and running down phases. Its length should be calculated so that there is no self-movement. The supply cable must not strike or rub against anything.

ATTENTION

If two unbalanced mass vibration generators of one vibration machine are connected to the mains supply, the connection cables of both unbalanced mass vibration generators must be connected to the same distribution box connection, without a detachable connection (no individual plug contacts). This measure prevents operation of only one of the unbalanced mass vibration generators of the vibration machine.

ATTENTION

If, contrary to this urgent recommendation, the two vibrators are connected to a distribution box, each with a detachable plug connection, suitable protection of the vibrating machine should be provided which prevents operation with only one unbalanced mass vibration generator. The manufacturer has provided a protection unit (cable fault relay) which should be installed for every unbalanced mass vibration generator.

The unbalanced mass vibration generator is to be protected against unacceptable heating up through overloading, non-starting, short-circuit or 2-phase running, by means of the monitoring units (motor protection switch or bimetal relay with fuses). The value for the starting current is given in the data sheet. Since unbalanced mass vibration generators start up under difficult conditions (increased working load, increased frictional losses at low temperatures in the cold state) it is recommended that a motor protection switch with delayed tripping characteristic is used

ATTENTION

If the unbalance vibrator is operated by a frequency converter the maximum speed or the maximum frequency must not exceed the nominal speed given on the rating plate. The frequency converter must be limited so that the frequency specified on the rating plate cannot be exceeded. The parameter block of the frequency converter must be switched on.

ATTENTION

The unbalance vibrator is equipped with a PTC Thermistor, which can be connected to the drive JV for temperature monitoring and must be connected with the drive JVA.

JV / JVA 130 °C

The unbalance vibrator in combination with a d.c. injection brake in the ex-area must be set so that the maximum current is not higher than the break-away starting current of the drive (see rating plate). The braking time must be set so that the d.c. injection brake is switched off approx. 1 sec. after machine standstill. In the case of multi-engine operation (conveying trough, sieve machine, etc.) the stator windings must be switched in series via the braking contactor for braking action.

The frequency converter and the d.c. injection brake must be set up in ex-free areas.

8. Setting the centrifugal force

8.1. Safety note

All setting operations on the unbalance vibrator must in principle only be carried out at rest. Before starting this work, ensure that the unbalance vibrator cannot be switched on accidentally or by unauthorized persons.



8.2. Setting instructions

The two protective covers of the unbalanced mass vibration generator should be removed so that the centrifugal weights under these are easily accessible.

The set centrifugal force can be read off on a % scale which is fitted on the inner centrifugal weights. The setting range is between 0% and 100%.

For setting each outer centrifugal weight (A) can be turned against the inner centrifugal weight (B) after unscrewing the locking screw (C).

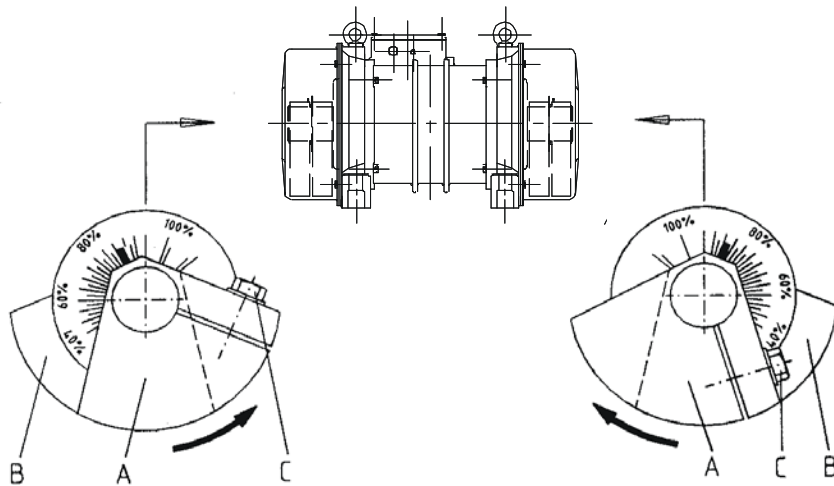

On both sides of the unbalanced mass vibration generator the centrifugal weights should be set to the required value (which can be read off on the % scale). The set values must be the same on both sides.

The clamping screws (C) of the centrifugal weights (A) must be tightened with a torque as specified in the table below.

Clamping screw Flyweight	
Thread	Torque MA (Nm) normal value
Convention	Nm
M 8	13
M 10	25
M 12	43
M 16	105
M 20	205

Before replacing the protective covers the set values of the centrifugal weights should be rechecked to ensure that they are the same.

The protective covers are then replaced, and correct fitting of the rubber seals checked. The fixing screws are hand tight, i.e. they should be tightened with the torque MA given in the table.

Unbalanced mass vibration generator	Thread	Torque MA (Nm)	Spanner opening
JV/JVA 28	M 10	7	17

9. Maintenance

9.1. Important notes

The unbalance vibrator must be regularly serviced. Inadequate maintenance can lead to faults or damage with consequent downtimes and repair costs. Correct maintenance ensures safety and reliability.

ATTENTION

All maintenance operations on the unbalance vibrator must on principle only be carried out when the unbalance vibrator is at rest. Before starting work, ensure that the unbalance vibrator cannot be switched on accidentally or by unauthorized persons.



9.2. Lubrication

The unbalance vibrator is lubricated in the works with the grease specified in the data sheet.

Unbalance vibrators of type JV/JVA are designed for regreasing; lubricating nipples are provided on the bearing end plates for this purpose.

Regreasing should as far as possible be carried out while the unbalance vibrator is still at its operating temperature; after which the vibrator should be started up again and run for about a further 30 minutes. This procedure is particularly advisable when regreasing is carried out at ambient temperatures below 0° C

Regreasing should if possible only be carried out with the grease specified in the data sheet; taking into account item 9.2.13, other greases may, however, also be used according to the following list.

ATTENTION

Manufacturer	Type
TOTAL	Multis complex EP 2
DEA	Paragon EP 3
WINTERSHALL	Wiolub LTS2
ARAL	ARALUB MKL 3/HL 3

A lithium complex saponified grease must be used for unbalanced mass vibration generators. If special greases are used for special application conditions relubricating must be carried out only with the same grease type.

Regreasing intervals and grease quantities are given in the data sheet. Regreasing should be carried out at least once yearly.

ATTENTION

Type	Grease per bearing (g)	Regreasing period per bearing (g)	Regreasing period (h) at speed $n = \text{min}^{-1}$			
			3000	1500	1000	750
JV/JVA 28	100 (NJ 318)	35	-	1500	2500	3000
	180 (NJ 2318)	55		1500	2500	3000

The regreasing intervals given in the data sheet are based on a bearing bracket surface temperature of up to 85°C.

If this temperature is exceeded by up to 15°C in each case the regreasing interval is halved.

For the first regreasing after commissioning, double the grease quantity of that given in the data sheet should be used.

Storage of the JV unbalance vibrator:

Until 12 months	10 hours after starting up, bearing relubricate
12 – 36 months	Centrifugal weights take off. 10 Hours after starting up, bearing relubricate
Over 36 months	Centrifugal weights take off. Before Starting up, bearing wash out and fill in new grease.

Roller bearings which have been cleaned or replaced should be greased with the grease quantity given in the data sheet.

9.3. Other maintenance / inspection operations

After the first 50 operating hours the fixing screws must be retightened with the tightening torque specified in the data sheet. The fixing screws of the protective covers and of the terminal box cover must also be retightened.

ATTENTION

The connecting cable must be examined for wear and breakages regularly and replaced if necessary.

Faulty operation in the form of changed noise development can be corrected with the fault tracing chart below.

Cause of the fault	Remedy
Fixing screws of the unbalance vibrator are loose	Check foot- and bolt contact surfaces for sound condition. Tighten screws with the specified torque (see data sheet).
Damage to bearings	Change the unbalance vibrator
Damage to the housing	Change the unbalance vibrator
Covers damaged	Change the covers

For the JVA unbalanced mass vibration generator the maximum surface temperature on the stator outside housing must not exceed 120°C in continuous operation.

10. Spare parts

10.1. Important notes

The manufacturer only guarantees original spare parts. When using non-original spare parts the functioning of the unbalance vibrators may be adversely affected and/or the safety impaired! The manufacturer does not accept responsibility for damage arising from the use of non-original spare parts!



When ordering spare parts, please quote the following data:

- unbalance vibrator type, mains voltage, electrical rating and frequency (see rating plate)
- manufacturer's motor no. (see rating plate)
- item- no.
- designation - see spare parts drawing/ spare parts list!
- quantity

10.2. Spare parts drawing/parts list

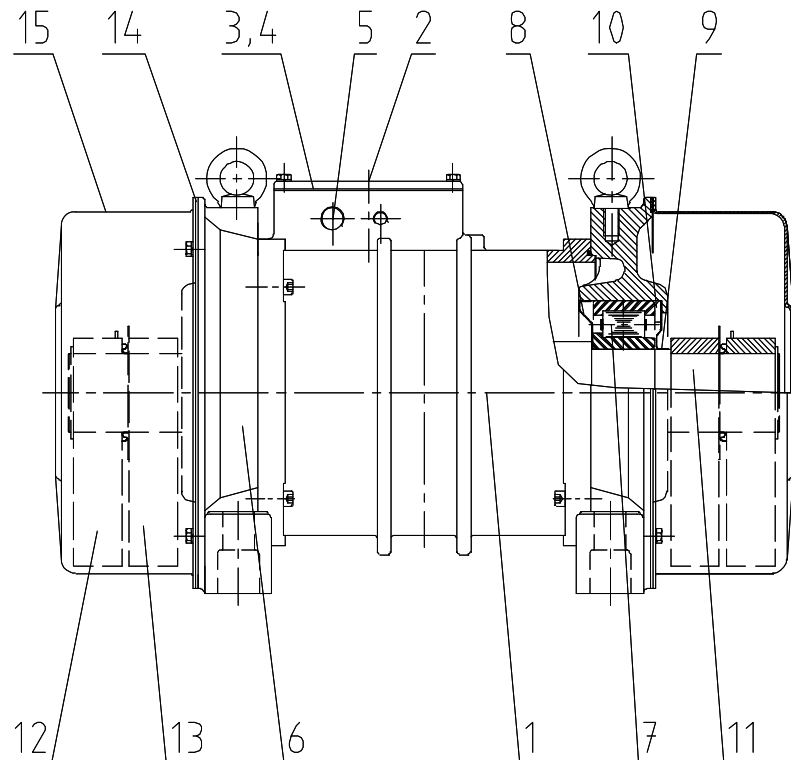

Item.	Designation	Quantity
1	Stator, complete	1
2	Terminal board	1
3	Terminal box cover	1
4	Gasket for terminal box cover	1
5	Cable union	1
6	Bearing end plate	2
7	Roller bearing	2
8	Sealing ring	2
9	Sealing ring	2
10	Spacer ring	2
11	Rotor	1
12	'External' centrifugal weight	2
13	'Internal' centrifugal weight	2
14	Gasket for cover	2
15	Cover	2

11. Special designs

11.1 PTC resistor as additional protection

Unbalanced mass vibration generators of type JV/JVA can be protected with a PTC resistor (130 °C) against unacceptable temperature increase and destruction of the winding in case of a fault through overloading, increased ambient temperature, intermittent operation, high switching frequency and phase failure.

11.2 Pole reversing unbalance vibrator

Pole-changeable unbalanced mass vibration generators are constructed with a Dahlander (pole-changing) circuit or with two separate windings. They are designed for continuous operation S1 according to VDE 0530, and can be used for both directions of rotation.

Pole changing may be carried out only in one direction of rotation or with opposed direction of rotation from a standstill.

Starting up is guaranteed for all speeds at the rated voltage. Details given in the data sheet should be observed.

12 Connection data for mains supply connection – normal and unter EMC conditions

		Normal connection		Conditions (on frequency converter)			
		Connecting cable		Required cable gland	Shielded connecting cable		
Vibrator type	Thread	Required F mm ²	Allowed Ø mm	Size	Required F mm ²	Outs. Ø mm	Inside Ø mm
JV/JVA 28	M 25	4 x 2,5	9 - 17	MS-SC M25	4 x 2,5	9 – 16,5	Min. 7,5

13 Data sheet

See following page