

THIS DRAWING IS UNPUBLISHED. RELEASED FOR PUBLICATION
 © COPYRIGHT - By - ALL RIGHTS RESERVED.

| LOC | DIST | REVISIONS | | | |
|-----|------|-------------|---------------------------|-----------|-------|
| P | LTR | DESCRIPTION | DATE | DWN | APVD |
| FT | 47 | AM1 | REVISED PER ECO-15-003583 | 07MAR2015 | NK MZ |

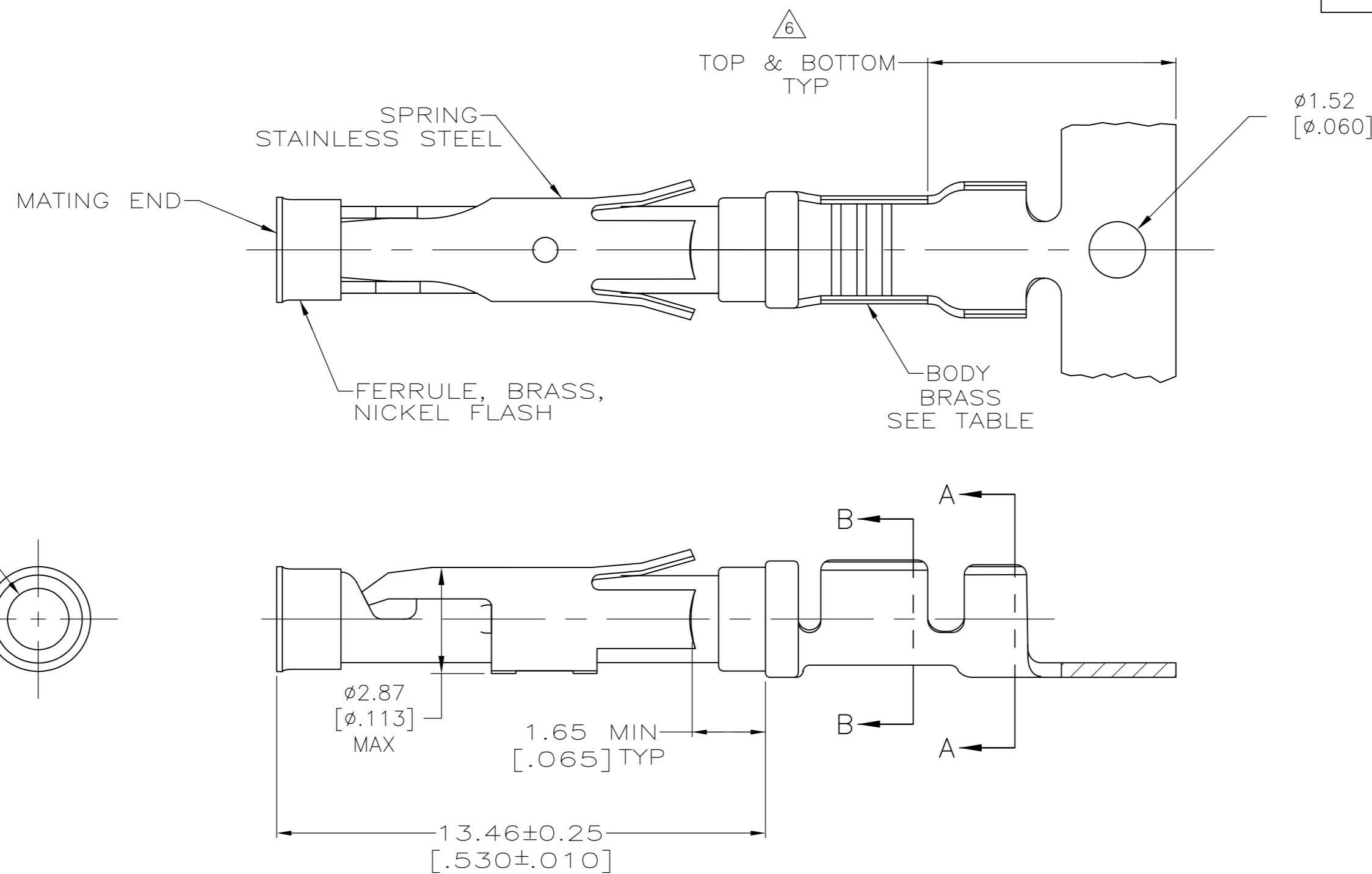

1.27µm [.000050] MIN TIN PER MIL-T-10727 OVER
 0.76µm [.000030] MIN NICKEL PER QQ-N-290.

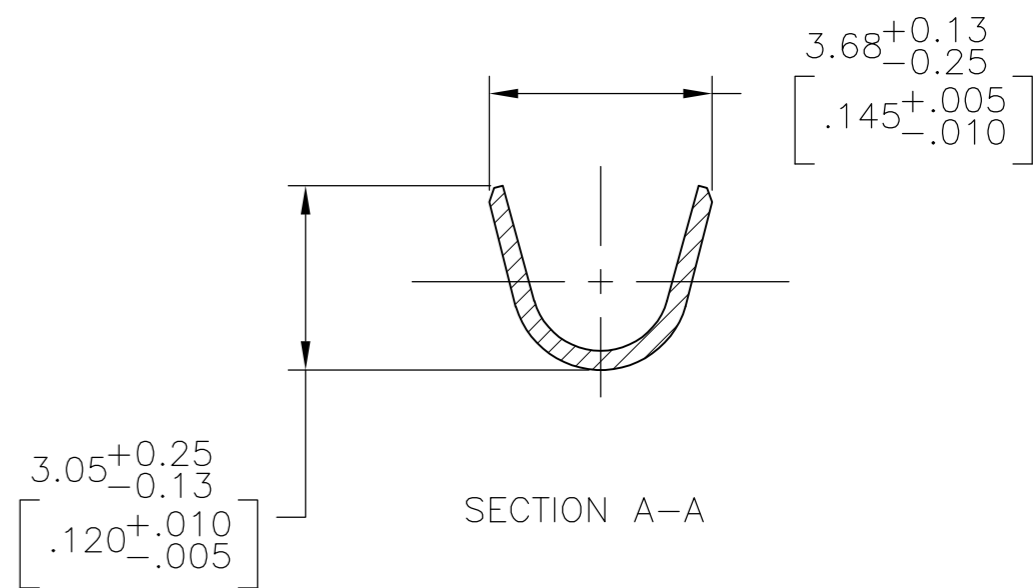
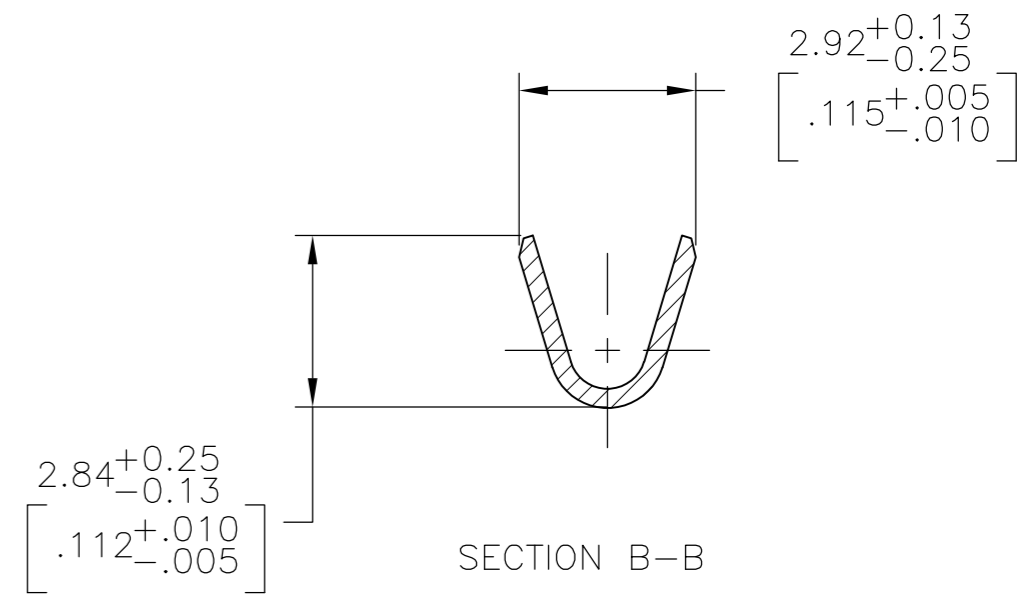
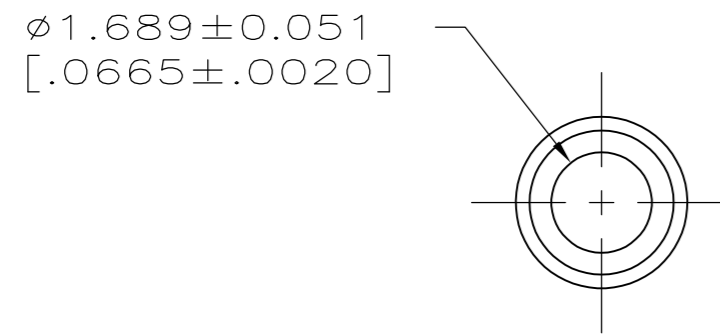

- 1 0.76µm [.000030] MIN GOLD PER MIL-G-45204 ON MATING END FOR A LENGTH OF 5.08 [.200] MIN WITH 1.27µm [.000050] MIN MATTE TIN PLATE IN WIRE CRIMP AREA, BOTH OVER 0.76µm [.000030] MIN NICKEL PER QQ-N-290.
- 2 1.27µm [.000050] MIN TIN-LEAD PER MIL-T-10727 OVER 0.76µm [.000030] MIN NICKEL PER QQ-N-290.
- 3 0.76µm [.000030] MIN GOLD PER MIL-G-45204 ON MATING END FOR A LENGTH OF 5.08 [.200] MIN WITH A UNIFORM GRADIENT TO 0.25µm [.000010] MIN GOLD PER MIL-G-45204 ON THE REMAINDER OVER 0.76µm [.000030] MIN NICKEL PER QQ-N-290.
- 4 0.38µm [.000015] MIN GOLD PER MIL-G-45204 ON MATING END FOR A LENGTH OF 5.08 [.200] MIN WITH 1.27µm [.000050] MIN MATTE TIN PLATE IN WIRE CRIMP AREA, BOTH OVER 0.76µm [.000030] MIN NICKEL PER QQ-N-290.
- 5 1.27µm [.000050] MIN GOLD PER MIL-G-45204 ON MATING END FOR A LENGTH OF 5.08 [.200] MIN WITH GOLD FLASH ON REMAINDER OVER 1.90µm [.000075] MIN NICKEL PER QQ-N-290.
- 6 GOLD PLATING NEED NOT APPEAR IN THIS AREA EXCEPT 1-66100-3 HAS GOLD PLATING ON INSULATION BARREL.
- 7 REVERSE REELED FOR MINI-APPLICATOR.
- 8 ALL PART NUMBERS ON THIS DRAWING HAVE APPLICATION TOOLING AVAILABLE TO CRIMP 18-16 WIRE AWG WITH AN INSULATION RANGE OF Ø2.03-2.54 [.080-.100]. ADDITIONALLY, LOOSE PIECE AND REVERSE REELED PART NUMBERS HAVE APPLICATION TOOLING AVAILABLE TO CRIMP 0.75mm² WIRE WITH AN INSULATION RANGE OF Ø1.35-1.65 [.053-.065] OR 1.0mm² WIRE WITH AN INSULATION RANGE OF Ø1.45-1.80 [.057-.071].
- 9 0.38µm [.000015] MIN GOLD PER MIL-G-45204 ON MATING END FOR A LENGTH OF 5.08 [.200] MIN, 1.27µm [.000050] MIN TIN-LEAD PER MIL-T-10727 FOR A LENGTH OF 5.69 [.224] MIN ON OPPOSITE END, BOTH OVER 1.27µm [.000050] MIN NICKEL PER QQ-N-290 ON ENTIRE CONTACT.

SUPERCEDED BY 66100-8
 OBSOLETE

| TE ASSEMBLY LOCATION | REELING | BODY FINISH | LOOSE PIECE REF | PART NO. |
|----------------------|----------|-------------|-----------------|-----------|
| EUROPE | 7 | 10 | NONE | 2-66100-2 |
| | 7 | 1 | NONE | 2-66100-1 |
| | STANDARD | 10 | 1-66101-9 | 2-66100-0 |
| | 7 | 10 | 1-66101-9 | 1-66100-9 |
| | 7 | 9 | 1-66101-4 | 1-66100-7 |
| | - | 5 | - | 1-66100-3 |
| | 7 | 1 | 66101-4 | 66100-9 |
| | 7 | 4 | 66101-3 | 66100-8 |
| | 7 | 2 | 66101-2 | 66100-7 |
| | 7 | 3 | 66101-1 | 66100-6 |
| NORTH AMERICA | STANDARD | 1 | 66101-4 | 66100-4 |
| | STANDARD | 4 | 66101-3 | 66100-3 |
| | STANDARD | 2 | 66101-2 | 66100-2 |
| | STANDARD | 3 | 66101-1 | 66100-1 |
| | STANDARD | 3 | 66101-1 | 66100-1 |

THIS DRAWING IS A CONTROLLED DOCUMENT.

| | | | |
|-------------------------|--|-----------------------------|---------------------------------------|
| DIMENSIONS: mm [INCHES] | TOLERANCES UNLESS OTHERWISE SPECIFIED: | DWN V. FURLER 11JUL03 | TE Connectivity |
| | 0 PLC ± - | CHK G. STEINHAEUER 11JUL03 | |
| | 1 PLC ± - | APVD G. STEINHAEUER 11JUL03 | |
| | 2 PLC ± 0.13 [.005] | PRODUCT SPEC | |
| MATERIAL SEE CALLOUTS | FINISH SEE CALLOUTS | APPLICATION SPEC | NAME SOCKET ASSEMBLY, .062, TYPE III+ |
| | | WEIGHT - | SIZE A2 |
| | | CUSTOMER DRAWING | CAGE CODE 00779 |
| | | | DRAWING NO C=66100 |
| | | | RESTRICTED TO - |
| | | | SCALE 8:1 |
| | | | SHEET 1 OF 1 |
| | | | REV AM1 |